



Fire Your Imagination

Riva2 400

Inset Convector Fire - Conventional Flue
with Thermostatic Remote Control



Instructions for Use, Installation & Servicing

For use in GB & IE (Great Britain & Republic of Ireland).

IMPORTANT

THE OUTER CASING, FRONT AND GLASS PANEL BECOME EXTREMELY HOT DURING OPERATION AND WILL RESULT IN SERIOUS INJURY AND BURNS IF TOUCHED. IT IS THEREFORE RECOMMENDED THAT A FIREGUARD COMPLYING WITH BS 8423 (LATEST EDITION) IS USED IN THE PRESENCE OF YOUNG CHILDREN, THE ELDERLY OR INFIRM.

This product contains a Heat resistant glass panel. This panel should be checked during Installation and at each servicing interval. If any damage is observed on the front face of the glass panel (scratches, scores, cracks or other surface defects), the glass panel must be replaced and the appliance must not be used until a replacement is installed. Under no circumstances should the appliance be used if any damage is observed, the glass panel is removed or broken.

It is essential that ALL of the screws that retain the glass frame are replaced and tightened correctly. Under no circumstances should the appliance be operated if any of these screws are loose or missing.

These Instructions must be left with the appliance for future reference and for consultation when servicing the appliance. Please make the customer aware of the correct operation of the appliance before leaving these instructions with them.

The commissioning sheet found on Page 3 of this Instruction manual must be completed by the Installer prior to leaving the premises.

Contents

Riva2 400 - Conventional Flue

Covering the following models:

Riva2 400 Nat Gas	Riva2 400 LPG
134-023	134-407

Appliance Commissioning Checklist	3
User Instructions	4
Installation Instructions	11
Technical Specifications	11
Site Requirements	13
Installation	16
Commissioning	26
Servicing Instructions	27
Fault Finding	27
How to Replace Parts	29
Basic Spare Parts List	36
Service Records	38
Information Requirement - Gas Heaters	39



If you have purchased your stove or fire from an authorised stockist within our Expert Retailer Network, then automatically your product will carry a 2 year warranty as standard. The 2 year warranty can be further extended to a total warranty period of 5 years by registering your Gazco Stove or Fireplace within one month of the latter of the purchase date or installation date. Accordingly, the start date for the warranty period is the date of purchase. During the registration process, the Expert Retailer details will be required for your Extended Warranty to be activated. Any product purchased outside of our Expert Retailer Network will carry a standard 12 month, non-extendable warranty.

It is a condition of the Extended Warranty that the installation complies with the relevant Building Regulations and is carried out by a suitably trained and qualified individual (GasSafe in the UK or equivalent in other countries) with the certificate of installation and the Commissioning Report on Page 3 completed and retained by the end user.

Full terms and conditions are detailed in the Warranty Statement on the Gazco website www.gazco.com. In the event of any conflict of information the wording on the website shall prevail.

Important Note: Should any problems be experienced with your product, claims must first be submitted to the Expert Retailer where the appliance was purchased from who will offer immediate assistance or contact Gazco on your behalf.



It is a requirement of the Building Regulations 2010 that the installation of this appliance is notified to the Local Authority. It is the responsibility of the GasSafe registered installer to carry out this notification to the Local Authority via the GasSafe register Competent Persons Scheme in England and Wales (different rules apply in Scotland and Northern Ireland).

When the installation has been notified, GasSafe will send a Building Regulations Compliance Certificate to you containing details of the work completed. Please ensure that the person responsible for the installation of this appliance completes this notification and records it in the Appliance Commissioning Checklist on page 3.

IT IS YOUR RESPONSIBILITY TO COMPLY WITH THE BUILDING REGULATIONS AND BE ABLE TO PRODUCE THIS CERTIFICATE SHOULD IT BE REQUIRED IN THE FUTURE.

Appliance Commissioning Checklist

To assist us in any guarantee claim please complete the following information:-

IMPORTANT NOTICE

Explain the operation of the appliance to the end user, hand the completed instructions to them for safe keeping, as the information will be required when making any guaranteed claims.

FLUE CHECK	PASS	FAIL
1. Flue Is correct for appliance		
2. Flue flow Test		
3. Spillage Test		
GAS CHECK		
1. Gas soundness & let by test		
2. Standing gas pressure	mb	
3. Appliance working pressure (on High Setting) Minimum Pressure Requirement: NG - 17.5mbar LPG - 34.5mbar NB All other gas appliances must be operating on full	mb	
4. Gas rate	m ³ /h	
5. Does Ventilation meet appliance requirements		
SAFETY CHECK		
1. Check soundness of the Thermocouple connections - including tightness and lead integrity		
2. Glass checked to ensure no damage, scratches, scores or cracks		
3. Glass frame secured correctly and all screws replaced		
BUILDING CONTROL NOTIFICATION	YES	NO
1. Installer notified GasSafe/Local Authority of installation via Competent Persons Scheme?		

RETAILER AND INSTALLER INFORMATION

Retailer	Installation Company
.....
.....
Contact No.....	Engineer.....
Date of Purchase.....	Contact No.....
Model No.	GasSafe Reg No.
Serial No.....	Date of Installation
Gas Type	

User Instructions

Welcome

Congratulations on purchasing your Riva2 fire, if installed correctly Gazco hope it will give you many years of warmth and pleasure for which it was designed.

The purpose of this manual is to familiarise you with your appliance, and give guidelines for its installation, operation and maintenance. If, after reading, you need further information, please do not hesitate to contact your Gazco retailer.

WARNING



In the event of a gas escape or if you can smell gas, please take the following steps:

- Immediately turn off the gas supply at the meter/emergency control valve
- Extinguish all sources of ignition
- Do not smoke
- Do not operate any electrical light or power switches (On or Off)
- Ventilate the building(s) by opening doors and windows
- Ensure access to the premises can be made

Please report the incident immediately to the National Gas Emergency Service Call Centre on 0800 111 999 (England, Scotland and Wales) , 0800 002 001 (N. Ireland) or in the case of LPG, the gas supplier whose details can be found on the bulk storage vessel or cylinder.

The gas supply must not be used until remedial action has been taken to correct the defect and the installation has been recommissioned by a competent person.

1. General

- 1.1 Installation and servicing must only be carried out by a competent person whose name appears on the GasSafe register. To ensure the engineer is registered with GasSafe they should possess an ID Card carrying the following logo:



- 1.2 In all correspondence, please quote the appliance type and serial number, which can be found on the data badge located on a plate attached to the lower slotted trim.
- 1.3 Do not place curtains above the appliance: You must have 300mm clearance between the appliance and any curtains at either side.

- 1.4 No furnishings or other objects should be placed within 1 metre of the front of the appliance.
- 1.5 If a shelf is fitted, a distance of 150mm above the appliance is required.
- 1.6 If any cracks appear in the glass panel do not use the appliance until the panel has been replaced.
- 1.7 This product is guaranteed for 5 years from the date of installation, as set out in the terms and conditions of sale between Gazco and your local Gazco retailer. Please consult with your local Gazco retailer if you have any questions. In all correspondence always quote the Model Number and Serial Number.



IMPORTANT: NEVER position a television or screen above this appliance.

2. Operating the Appliance

The appliance is operated by thermostatic remote control.

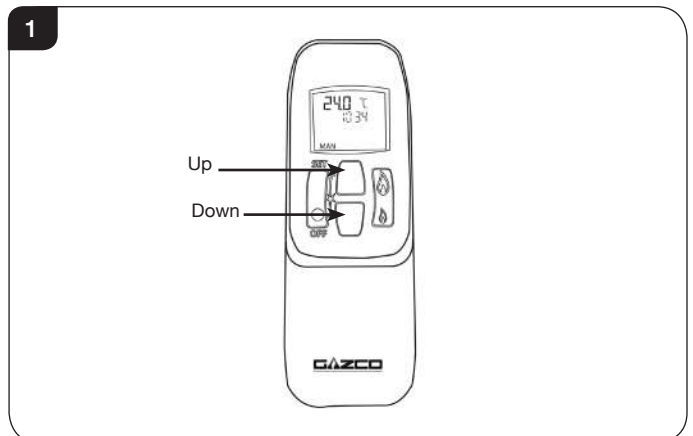

- 2.1 **Turning the appliance On**
Your remote can control the gas appliance from pilot ignition through to shut down.

To turn the appliance on press the OFF button and the UP button simultaneously. You hear several short signals. **The pilot and main burner ignite and the remote is now in Manual Mode:**



IMPORTANT: YELLOW FLAMES TYPICALLY APPEAR WHEN THE APPLIANCE HAS REACHED NORMAL OPERATING TEMPERATURE. THIS CAN TAKE UP TO 30 MINUTES.



WARNING: IF THE APPLIANCE FAILS TO LIGHT OR BECOMES EXTINGUISHED IN USE, WAIT 3 MINUTES BEFORE ATTEMPTING TO RELIGHT.

- 2.2 There are 3 different modes available for controlling and operating the appliance:
1. Manual Mode
 2. Temp Mode (Automatic)
 3. Timer Mode (Automatic)

User Instructions

2.3 In **MANUAL MODE** you can:

- Turn on the main burner using the UP button.
- Regulate the flame from high to low and back.
- Turn off the burner leaving just the pilot burning.

In **TEMP MODE (Automatic)** you can:

- Set the room temperature so the thermostat in the remote automatically maintains that temperature.

In **TIMER MODE (Automatic)** the appliance:

- Turns on and off according to the set time periods.
- Automatically regulates the room temperature during the set periods.

i **NOTE: When operating the appliance in Temp or Timer mode, the pilot remains lit and the appliance then automatically switches on at programmed times to bring the room to the set temperature whether or not you are in the room. NEVER LEAVE ANY COMBUSTIBLE MATERIALS WITHIN 1 METRE OF THE FRONT OF THE APPLIANCE.**

Switching Between Modes

2.4 Press the SET button to change to Temperature Mode. Press again to change to Timer Mode. Keep pressing to run through all operating modes.

These are:

- MAN
 - DAY TEMP
 - NIGHT TEMP
 - TIMER
- and back to MAN

NOTE: MAN mode can also be reached by pressing either the UP or DOWN button.

Manual Mode

2.5 Press the OFF button and the UP button simultaneously. You hear several clicks and audible beeps as the appliance begins the ignition process, (up to 30 seconds).

Turning the appliance Off:

Press the OFF button to turn the appliance off.

FOR SAFETY, YOU MUST WAIT 30 SECONDS BEFORE LIGHTING THE APPLIANCE AGAIN.

Increasing the Flame Height:

Press the UP button once to increase flame height one stage. Press and hold the UP button to increase to maximum.

Decreasing the Flame Height:

Press the DOWN button once to decrease flame height one stage. Press and hold the DOWN button to decrease to minimum. At the lowest point the appliance goes to 'Standby Mode' (Only Pilot lit).

i **NOTE: While pressing a button a symbol indicating transmission appears on the display. The receiver confirms transmission with a sound signal.**

Temp Mode (Automatic)

2.6 The display shows the current **room** temperature.

To increase or decrease the appliance's output:

Press the SET button to select either the DAY TEMP or the NIGHT TEMP mode by briefly pressing the SET button.

Hold the SET button until the TEMP display flashes and then let go.

Set the desired temperature with the UP and DOWN arrows. (Minimum temperature 5C, maximum 40C or 40F to 99F when Fahrenheit is the preferred option).

Press the OFF button to stop the display flashing or wait to return to TEMP mode.

i **NOTE: If you set a temperature that is beneath the current room temperature, the appliance automatically switches to PILOT (Stand by).**

If you would like the **Night** temperature control to turn off then decrease the temperature until [-] is displayed.

Timer Mode (Automatic)

2.7 There are two programmable settings you can make over a 24 hour period, P1 and P2. These are normally used to provide an early morning and evening setting for each working week:

- P1 + ● = Start Timed Setting 1
- P1 + ☞ = End of Timed Setting 1
- P2 + ● = Start Timed Setting 2
- P2 + ☞ = End of Timed Setting 2

2.8 **P1 - Program 1 for a Timed Setting**

Press the SET button until the TIMER mode is displayed.

Hold the SET button. The displays flashes the current time for P1. **While the time displayed is flashing you can alter the hours and minutes set.**

To set the time your appliance first lights, change P1 ●

- Press the UP button to alter the hour.
- Press the DOWN button to alter the minutes in 10 minute increments.

Press SET again to move to the end setting for P1 ☞ This is the time your appliance first shuts down:

- Press the UP button to alter the hour.
- Press the DOWN button to alter the minutes.

User Instructions

2.9 P2 - Program 2 for a Timed Setting

Use the same steps outlined in 2.8 to change the setting for P2.
If you have already set P1 and want to alter the setting for P2 only:

- Press the SET button until TIMER mode is displayed.
- Hold the SET button **until the display flashes the current time** for P1.
- Press the SET button once again to scroll past the settings for P1 and P1.

With the time still flashing:

- Press the UP button to alter the hour.
- Press the DOWN button to alter the minutes.

Once all four times are set press the OFF button.

2.10 To view existing settings:

- Select Timer Mode.
- Press and briefly hold the SET button you see the start time for P1.
- Repeat the above step for the start and end of each program.

Low Battery

“BATT” is displayed on the remote when its batteries need replacement.

Setting the time

Simultaneously press the up and down buttons.

Press the up button to set the hour and the down button to set the minutes.

Press OFF to return to the manual mode or simply wait.

Setting the °C/24 Hour or °F/12 Hour clock

Press OFF and the down arrow until the display changes from °C/24 hour clock to °F/12 hour clock and vice versa.

i If the remote is removed, lost or damaged, signals transmitted to the receiver cease. Your appliance will go to standby (pilot) mode after 6 hours.

Troubleshooting



IMPORTANT: In the unlikely event that the handset fails to communicate correctly with the appliance it may be necessary to turn off the gas supply at the isolation valve until any problems can be resolved.

The gas meter and isolation valve can be located outside in a meter box, under the stairs, beneath the kitchen sink or in the garage. Whilst this list is not exhaustive, it is important to be able to identify the location of the valve in case of any gas emergency.

To turn off the gas supply, simply turn the handle so the lever is at 90 degrees to the upright gas pipe.

If you smell gas, open doors and windows and never operate any electrical switches. Immediately call the Gas Emergency Services on 0800 111 999.

3. Changing the Appliance Batteries

The appliance batteries are located on a bracket attached to the lower slotted trim.

- 3.1 Make sure the appliance and surrounds are cool before removing the batteries.
- 3.2 Remove the 2 side trims, see Diagram 2. These are held on by magnets.

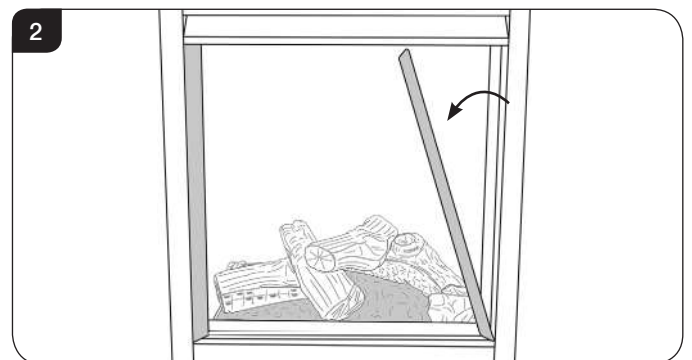

- 3.3 Lift out the bottom slotted trim, see Diagram 3. Note the orientation of the metal shield for reassembly.



User Instructions

- 3.4 Disconnect the battery lead from the battery pack attached to the lower slotted trim and remove, see Diagram 4.

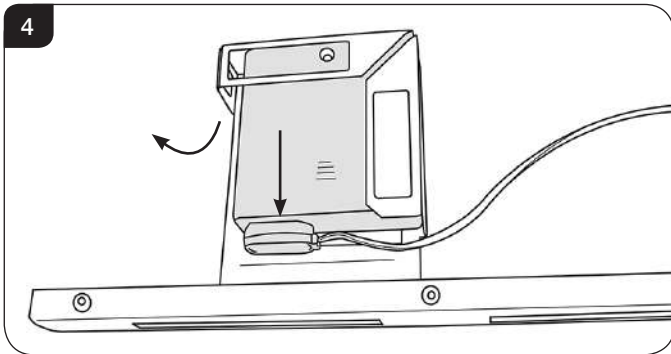

- 3.5 Remove the cover by sliding off in the direction of the arrow as shown in Diagram 5.

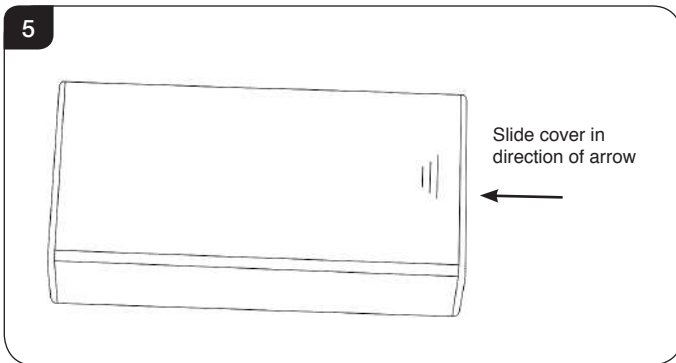

- 3.6 Correctly position the four new AA size batteries into the battery holder.

i It is essential to use high quality batteries (Duracell or equivalent) when replacing batteries in the handset or control box.

- 3.7 Re-assemble in reverse order, ensuring the cable runs down the right hand side of the battery holder.

! PLEASE ENSURE NO WIRES ARE TRAPPED BEFORE REPLACING THE LOWER SLOTTED TRIM. THE LEADS ARE EASILY DAMAGED.

4. Cleaning the Appliance

- 4.1 Make sure the appliance and surrounds are cool before cleaning.
- 4.2 Remove the glass frame by removing the 2 side trims, see Diagram 6. These are held on by magnets.



- 4.3 Lift out the bottom slotted trim, see Diagram 7. Note the orientation of the metal shield for reassembly.

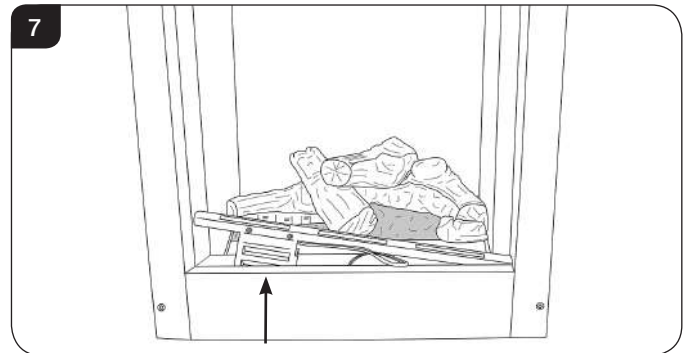

- 4.4 Disconnect the battery lead from the battery pack attached to the lower slotted trim and remove, see Diagram 8.

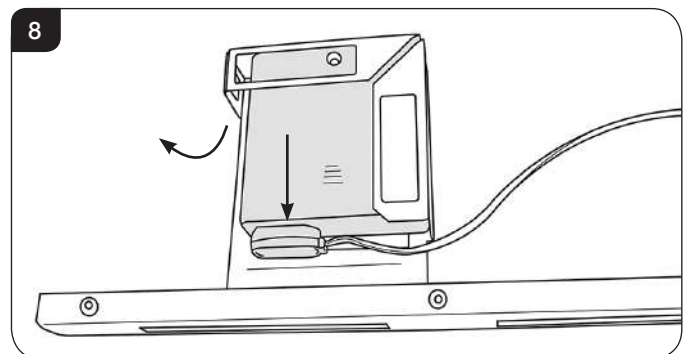

User Instructions

- 4.5 Remove the 2 screws at the base of the glass frame, see Diagram 9.

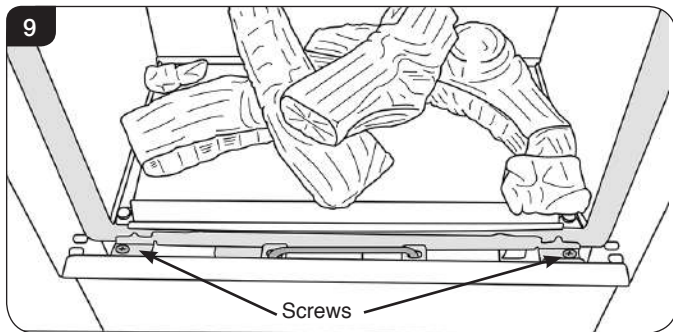

- 4.6 Pull up the handle at the front, see Diagram 9.
4.7 Whilst supporting the top, lift the door using the handle, up and over the lower edge, see Diagram 10.

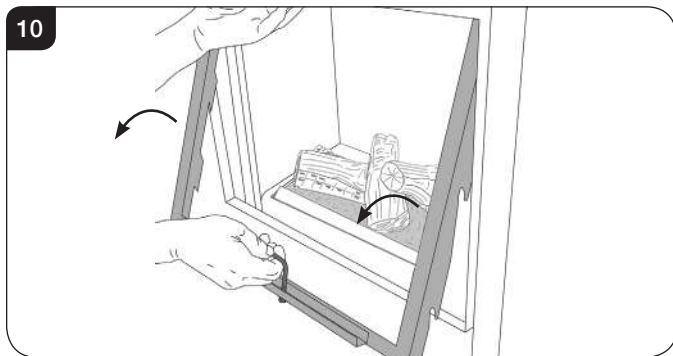

- 4.8 Remove the logs, and place them on a dry, clean surface.
4.9 The logs should not require cleaning. Do not use a vacuum cleaner or brush to clean the logs, any large pieces of debris may be removed by hand.
4.10 Ensure any debris is removed from the burner ports.
4.11 Use a damp cloth to clean the outer casing of the appliance.
4.12 To clean the glass surface use a non abrasive glass cleaner and soft cloth.
4.13 The glass frame must be refitted to the appliance following cleaning or servicing.

Ensure that the fibreglass seal on the back of the glass frame is intact.

- 4.14 To replace the glass frame, position so the hooks on the back of the frame fit over the side pins, see Diagram 11.

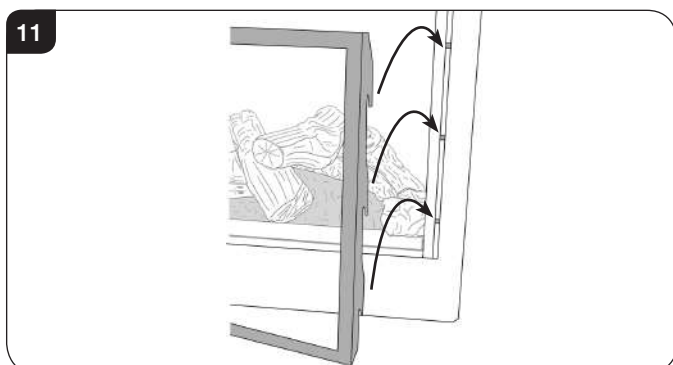

- 4.15 Push the handle down.
4.16 Replace the screws. As the screws are tightened the glass frame is pulled down against the hooks and forms a seal. **Replace ALL of the securing screws ensuring that a screw is present in all fixing slots.**



UNDER NO CIRCUMSTANCES SHOULD THE APPLIANCE BE USED IF ANY OF THE GLASS FRAME RETAINING SCREWS ARE LOOSE OR MISSING.

- 4.17 Replace the lower trim, ensuring that the angled metal shield is sloping towards the door frame.
4.18 Replace the 2 magnetic side trims.
4.19 Replace the decorative front by referring to the separate instructions supplied with the front.

NOTE: ENSURE THAT THE LOGS ARE POSITIONED CORRECTLY, SEE SECTION 6. ONLY USE THE CORRECT AMOUNT OF LOGS AS SPECIFIED IN THE DIAGRAMS.

5. Arrangement of Fuel Bed

Advice on handling and disposal of fire ceramics



The fuel effect in this appliance are made from Refractory Ceramic Fibre (RCF), a material which is commonly used for this application.

Protective clothing is not required when handling these articles, but we recommend you follow normal hygiene rules of not smoking, eating or drinking in the work area and always wash your hands before eating or drinking.

To ensure that the release of RCF fibres are kept to a minimum, during installation and servicing a HEPA filtered vacuum is recommended to remove any dust accumulated in and around the appliance before and after working on it. When servicing the appliance it is recommended that the replaced items are not broken up, but are sealed within heavy duty polythene bags and labelled as RCF waste.

RCF waste is classed as stable, non-reactive hazardous waste and may be disposed of at a licensed landfill site.

Excessive exposure to these materials may cause temporary irritation to eyes, skin and respiratory tract; wash hands thoroughly after handling the material.

User Instructions

6. Log Layout

LOGS MUST BE POSITIONED ACCORDING TO THE FOLLOWING INSTRUCTIONS TO GIVE THE CORRECT FLAME EFFECT.

All logs can be identified by a letter (A - D) on their underside. Logs A and B have holes to locate each onto a burner stud.

- 6.1 Ensure the burner tray is clean and free from any debris, see Diagram 12.

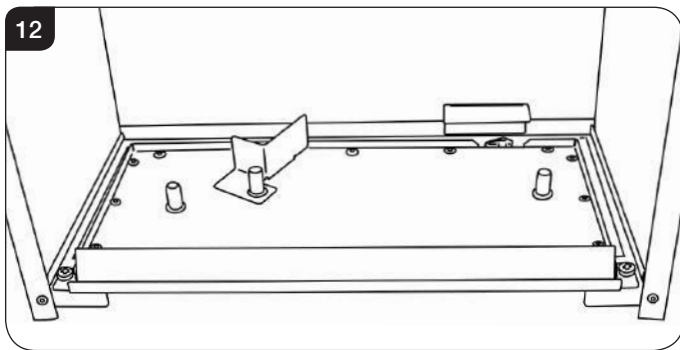

- 6.2 Place Log A in position on the 2 locating pins, see Diagram 13.

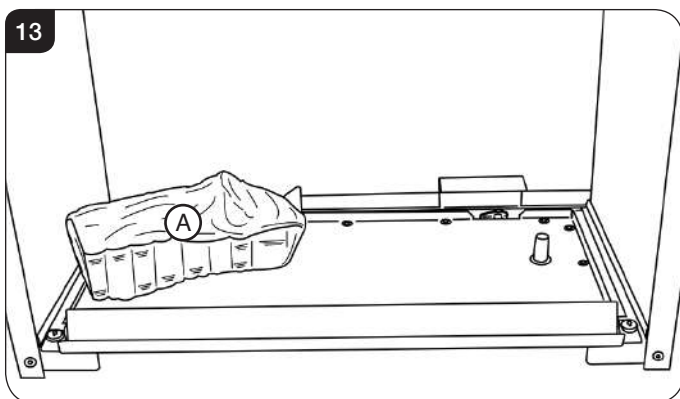

- 6.3 Spread the Lava Rock evenly over the fuel bed and around Log A, see Diagram 14.

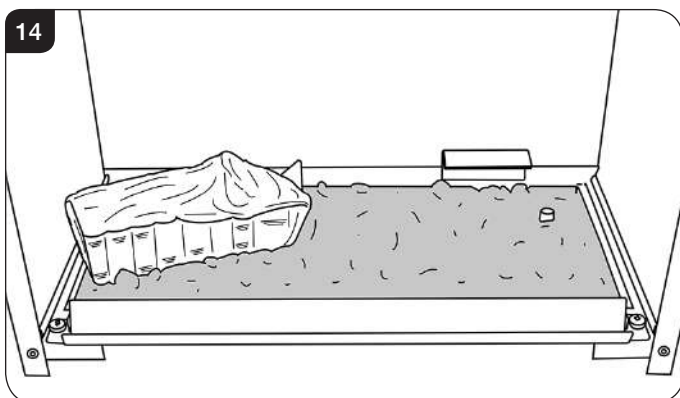

- 6.4 Log B is positioned on the right hand locating pin, and rests against the back liner, see Diagram 15.

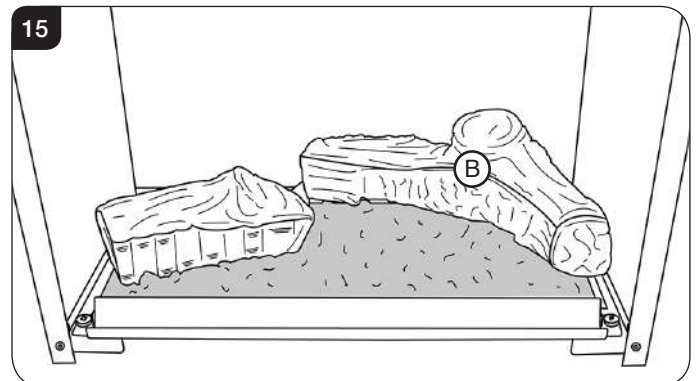

- 6.5 Log C rests on Log A and the front tray with the locating pin facing up, see Diagram 16.

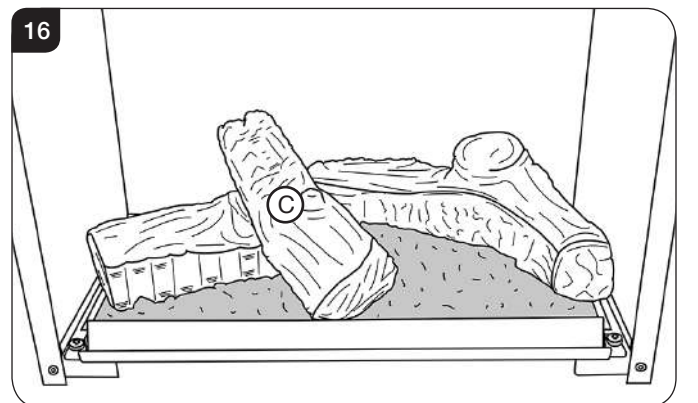

- 6.6 Log D fits onto the locating pin and rests on Log B, see Diagram 17.

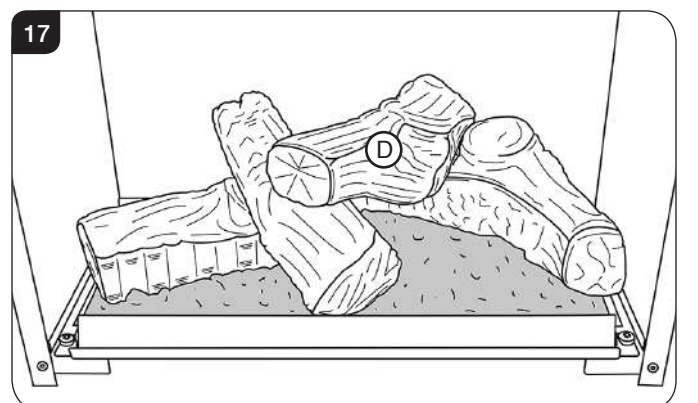

User Instructions

- 6.7 Position the 2 embers in the front right and back left corners, see Diagram 18.

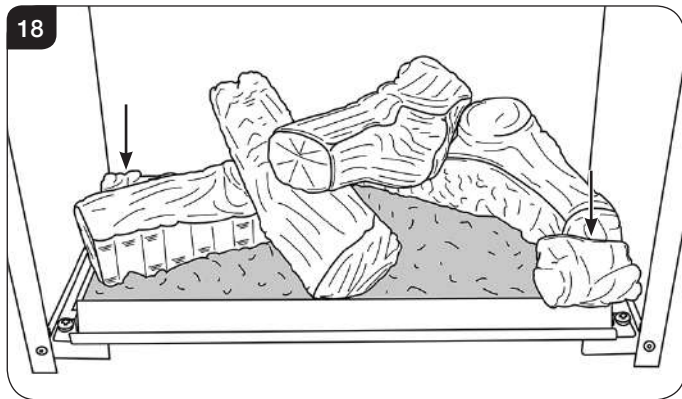

- 6.8 Sparingly spread an amount of the Embaglow fibres provided on the sections highlighted, see Diagram 19. Take care not to use more than half a packet per application.
WARNING - DO NOT PLACE NEAR THE PILOT AREA.

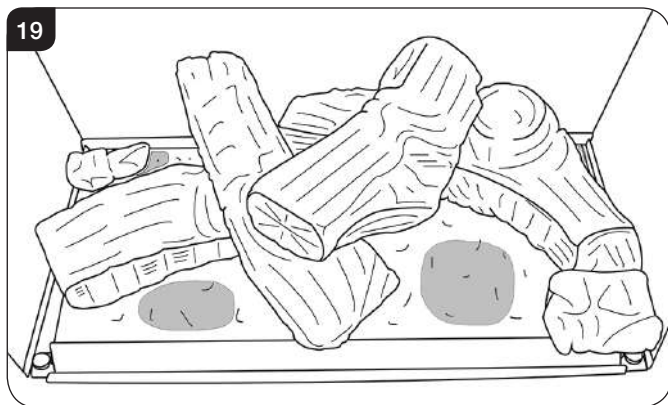

7. Oxygen Depletion Sensor

The appliance is fitted with an oxygen sensitive pilot system that will act to cut off the gas supply to the appliance should the oxygen in the room fall below its normal level. If the appliance is turned off by this device it usually indicates that there is a problem with the flue system, this should be inspected by a qualified engineer.

DO NOT ATTEMPT TO USE THE APPLIANCE UNTIL AN ENGINEER SAYS IT IS SAFE TO DO SO. THIS DEVICE IS NOT A SUBSTITUTE FOR AN INDEPENDENTLY MOUNTED CARBON MONOXIDE DETECTOR.

8. Flame Failure Device

- 8.1 This is a safety feature incorporated on this appliance which automatically switches off the gas supply if the pilot goes out and fails to heat the thermocouple.

IF THIS OCCURS DO NOT ATTEMPT TO RELIGHT THE APPLIANCE FOR 3 MINUTES.

9. Running In

- 9.1 During initial use of a new Gazco appliance a strong odour will be encountered as various surface coatings become hot for the first time. Although these odours are harmless it is recommended that the appliance is operated on maximum for 4 to 8 hours in order to fully burn off these coatings. After this period the odours should then disappear.
- If the odours persists, please contact your installer for advice.
- 9.2 During the first few hours of burning there may be discolouration of the flames. This will also disappear after a short period of use.

10. Servicing

- 10.1 The appliance must be serviced every 12 months by a qualified Gas Engineer. In all correspondence always quote the Model number and the Serial number which may be found on the Commissioning Checklist (Page 3).

11. Ventilation

- 11.1 Any purpose provided ventilation should be checked periodically to ensure that it is free from obstruction.

12. Installation Details

- 12.1 Your installer should have completed the commissioning sheet at the front of this book. This records the essential installation details of the appliance. In all correspondence always quote the Model number and Serial number.

13. Hot Surfaces

- 13.1 Parts of this appliance become hot during normal use.
- 13.2 Regard all parts of the appliance as a working surface.
- 13.3 Provide a suitable fire guard to protect young children and the infirm.

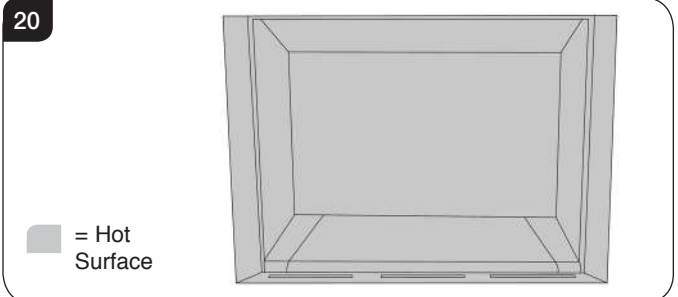

14. Appliance will not light

If you cannot light the appliance:

- 14.1 Check and change the batteries in the remote handset.
- 14.2 Check and change the wall plate batteries (see Section 3).
- 14.3 Consult your Gazco retailer or installer if the Riva2 400 still does not light.

Installation Instructions

Technical Specification

Covering the following models:

Riva2 400 Nat Gas	Riva2 400 LPG
134-023	134-407

Model	Gas CAT.	Gas Type	Working Pressure	Aeration	Injector	Gas Rate m ³ /h	Input kW (Gross)		Country
							High	Low	
Riva2 400	I ₂ H	Natural Gas	20mbar	2 x 4mm Ø	170	0.491	5.2	2.6	GB, IE
Riva2 400	I ₃ P	Propane	37mbar	2 x 12mm Ø	150	0.189	5.1	2.5	
Efficiency Class 2 - 76% / NO_x Class 4									
Flue Size - TOP EXIT Ø 127mm									
Flue Size - REAR EXIT 178mm ø minimum									
Gas Inlet Connection Size Ø 8mm									
Minimum Flue Specification = T250/N2/0/D/1									
Maximum Flue Temp = 230°C									



The net efficiency of this appliance has been measured as specified in EN613:2001 and the result after conversion to gross using the appropriate factor from Table E4 of SAP 2012 is 70%. The test data has been certified by Kiwa Nederland BV. The gross efficiency value may be used in the UK Government's Standard Assessment Procedure (SAP) for energy rating of dwellings.

Installation Instructions

Technical Specification

This appliance has been certified for use in countries other than those stated. To install this appliance in these countries, it is essential to obtain the translated instructions and in some cases the appliance will require modification. Contact Gazco for further information.

PACKING CHECKLIST

Qty. Description	Fixing kit containing
1 x Cassette and burner assembly	1 x Instruction manual
1 x Back panel	6 x Woodscrews
1 x LH side panel	6 x Wall plugs
1 x RH side panel	1 x Self adhesive foam strip
1 x Log set (6 logs)	1 x Handset
1 x Blanking Plate	4 x AA cell batteries
1 x Restrictor (rear exit)	1 x 9v cell battery

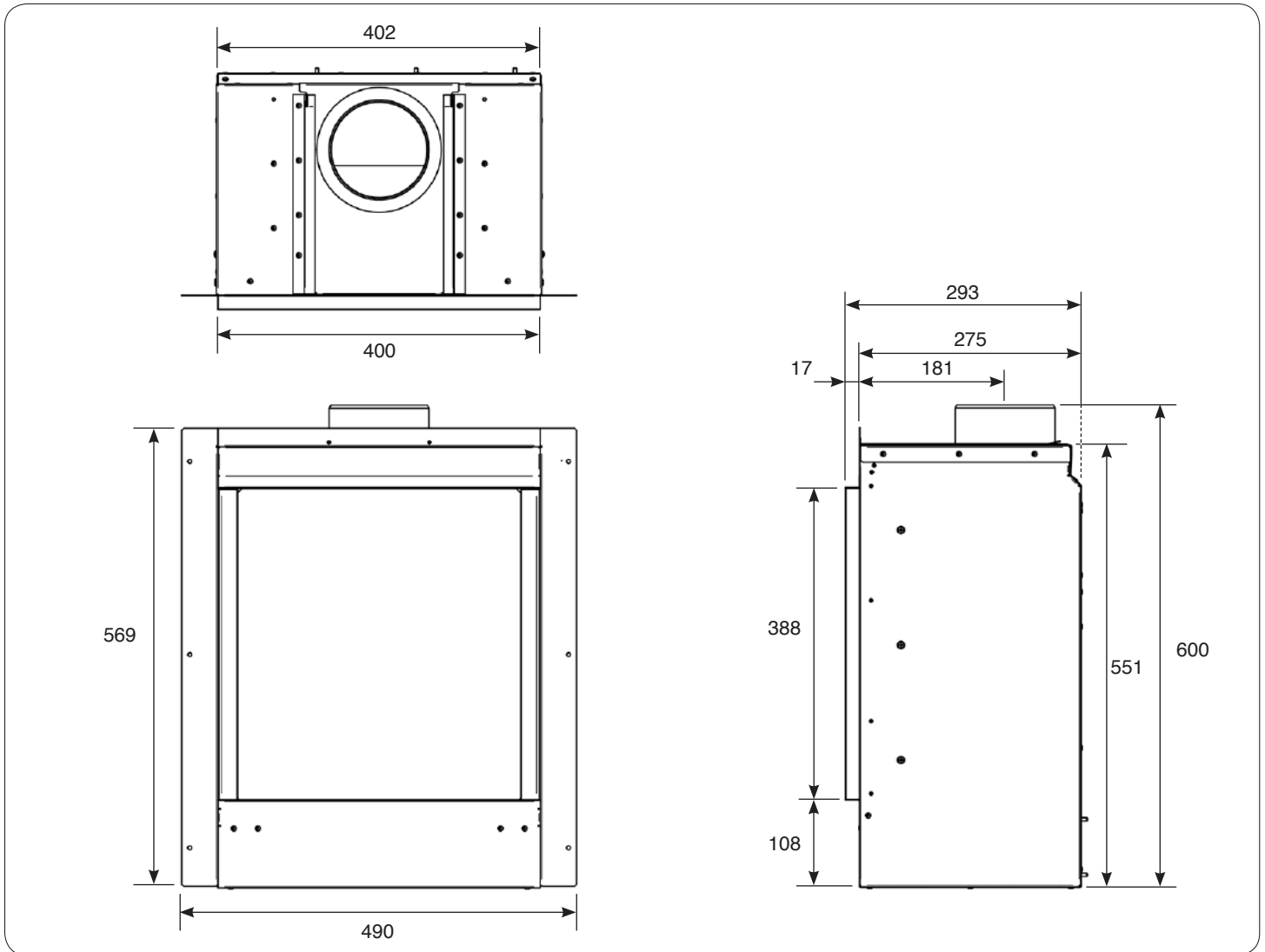

Installation Instructions

Site Requirements

1. Flue & Chimney Requirements

WHEN INSTALLING A FLUE SYSTEM PLEASE REFER TO THE MANUFACTURER'S INSTRUCTIONS.

The European chimney standards now describe chimneys and flues by their temperature, pressure and resistance to corrosion, condensation and fire. To identify the correct flue system, the minimum flue specification is shown in the Technical Specification. Existing chimneys are not covered by this system.

The flue must be installed in accordance with all local and national regulations and the current rules in force:

- 1.1 The chimney or flue system must comply with the rules in force, and must be 127mm (5") in diameter.
- 1.2 A flexible liner must be continuous from the appliance spigot to the roof terminal.
- 1.3 The minimum effective height of the flue must be 3m (10').
- 1.4 The flue must be free from any obstruction.
- 1.5 Any damper plates must be removed or secured in the fully open position and no restrictor plates fitted.
- 1.6 The chimney should be swept immediately before installing the appliance, but it need not be swept if you can see the chimney is clean and free from obstruction throughout.
- 1.7 A flue restrictor is provided with this appliance. This can be fitted when the flue is equal to or greater than 7" or when the flue pull is excessive, see Diagram 1.

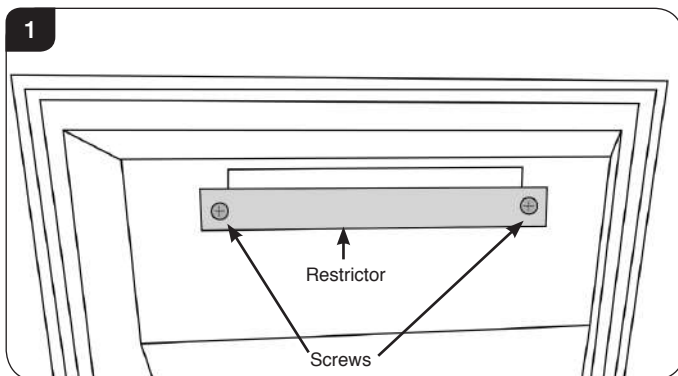

This is fitted from outside the appliance across the outlet at the top of the box with 2 screws provided.

- 1.8 A flexible liner must be continuous from the appliance spigot to the roof terminal.
- 1.9 The minimum effective height of the flue must be 3m (10').
- 1.10 The flue must be free from any obstruction.
- 1.11 Any damper plates must be removed or secured in the fully open position and no restrictor plates fitted.

- 1.12 The chimney should be swept immediately before installing the appliance, but it need not be swept if you can see the chimney is clean and free from obstruction throughout.
- 1.13 Ensure that there is a smooth taper transition from the fireplace opening into the chimney or flue.
- 1.14 The flue pull should be checked prior to installation of the appliance. Apply a smoke pellet to the flue or chimney opening and ensure that the smoke is drawn into the opening. If there is not a definite flow, preheat the chimney for a few minutes and re-test the flow.

IF THERE IS STILL NO DEFINITE FLOW, THE CHIMNEY MAY REQUIRE ATTENTION - SEEK EXPERT ADVICE.

2. Flue Options

There are three main suitable Conventional Flues:

- Top Exit - Builder's Opening Lined
127mm (5")
- Rear Exit - Builder's Opening Unlined
178mm (7") minimum
- Studwork is Top Exit only - Rigid Twin Wall Flue Pipe
127mm (5")

3. Gas Supply

This appliance is intended for use on a gas installation with a governed meter.

- 3.1 Make sure local distribution conditions (identification of the type of gas and pressure) and the adjustment of the appliance are compatible before installation.
- 3.2 Ensure the gas supply delivers the required amount of gas and is in accordance with the rules in force.
- 3.3 Soft copper tubing can be used on the installation and soft soldered joints outside the appliance and below the firebed.
- 3.4 A factory fitted isolation device is part of the inlet connection; no further isolation device is required.
- 3.5 All supply gas pipes must be purged of any debris that may have entered prior to connection to the appliance.
- 3.6 The gas supply enters through the silicone panel located on the LEFT-HAND side on the rear of the outer box. Slit with a sharp knife prior to passing the supply pipe through.
- 3.7 The gas supply must be installed in a way that does not restrict the removal of the appliance for servicing and inspection.

Installation Instructions

Site Requirements

4. Ventilation

IMPORTANT: Ensure any national ventilation requirements are taken into account during installation of the appliance.

UK ONLY:

The appliance has a nominal input not exceeding 7.0kW and does not normally require any additional permanent ventilation.

If however, spillage is detected when commissioning the appliance, there may be insufficient natural ventilation and additional ventilation may be required.

FOR THE REPUBLIC OF IRELAND REFER TO THE RULES IN FORCE FOR VENTILATION REQUIREMENTS.

5. Appliance Location

i If fitting this appliance with a decorative frame it cannot be installed with the base of the appliance less than 150mm from the floor level. The frame requires a minimum clearance to allow air to circulate.

If this appliance is fitted less than 150mm from the floor, then it will require a hearth to protect the floor. The hearth should have a minimum dimension of 12mm thick, projecting 300mm in front and 150mm either side of the appliance.

5.1 The minimum opening dimensions are shown in Diagram 2.

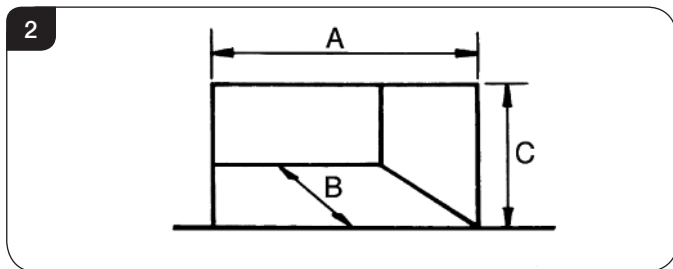

Dimension	Brick Built Class 1	Pre-Fab Metal Box
A	425	407
B	350	317
C	560	560

5.2 This appliance must not be installed in a room that contains a bath or shower.

5.3 **NOTE:** If using natural materials for the back panel of the fireplace, it is recommended that it is constructed from three or more sections to prevent cracking. Resin-based materials may not be suitable. This appliance is an effective heat producer and attention must be paid to the construction and finish of the fireplace.

5.4 When the appliance is installed in a masonry chimney without a liner, there must be a minimum debris collection area, see Diagram 3.

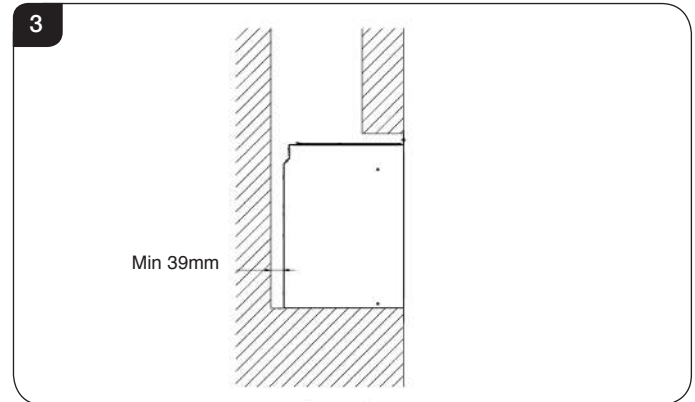

5.5 This appliance is not suitable for installation onto a combustible wall; all combustible materials must be removed from the area shown in Diagrams 4.

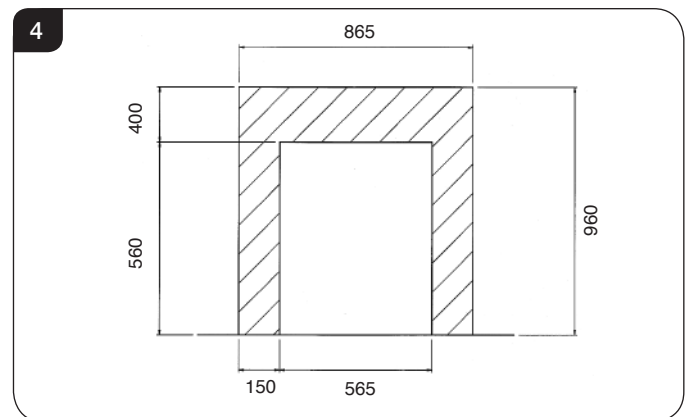

STUDWORK INSTALLATION

5.6 If a studwork installation is used (eg. wooden framework and plasterboard), combustible parts of the studwork must not be any closer than the minimum dimensions shown in the diagrams. **NOTE:** These dimensions must be maintained even if the combustible materials is protected by non-combustible linings.

5.7 Do not pack the void around or above the appliance with insulation materials such as mineral wool.

5.8 The void into which the cassette is fitted must be ventilated to prevent a build up of heat. If the void is sealed then it will be necessary to fit vents at both low and high levels of approximately 50cm² each. These vents should take cold air from the room and return warm air back into the room.

5.9 A removable access hatch must be left in the side of the chimney breast for future servicing and inspection of the appliance.

Site Requirements

- 5.10 Build the studwork chimney breast to the desired size. Ensure that the clearances to combustible materials is maintained.

PROTECT THE NEAREST STUDWORK WITH NON-COMBUSTIBLE MATERIAL AND MAINTAIN THESE DIMENSIONS AT ALL TIMES, SEE DIAGRAM 5.

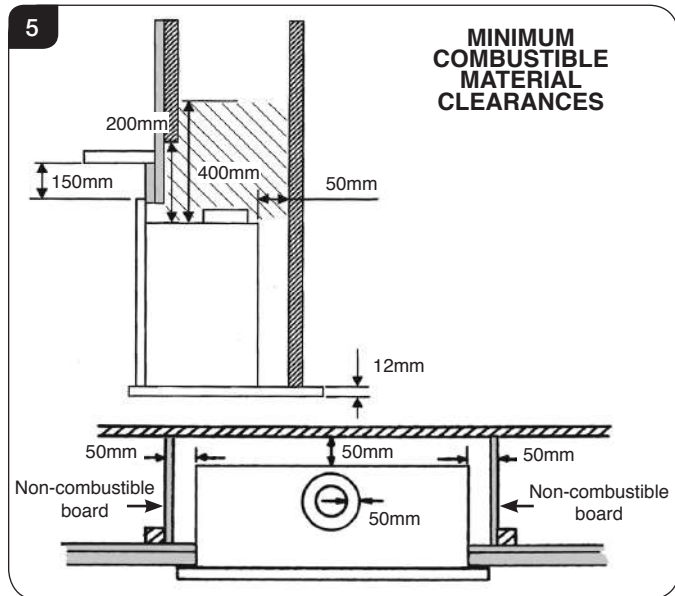

It is recommended that a marble slip or similar material is used when fitting cassette fireplaces into a plastered surface, in order to allow for heat dissipation. Also allow adequate time for newly plastered areas to dry out. Rapid drying can create cracks. If in doubt, seek the advice of a professional plasterer.

Parts of this appliance become hot during normal use. It is therefore recommended that a suitable fire guard be used for protection of young children and the infirm.

Installation Instructions

1. Safety Precautions

- 1.1 For your own and other's safety, you must install this appliance according to local and national codes of practice. Failure to install the appliance correctly could lead to prosecution. **Read these instructions before installing and using this appliance.**
- 1.2 These instructions must be left intact with the user.
- 1.3 Do not attempt to burn rubbish on this appliance.
- 1.4 Keep all plastic bags away from young children.
- 1.5 Do not place any object on or near to the appliance and allow adequate clearance above the appliance.

IF THE APPLIANCE IS EXTINGUISHED OR GOES OUT IN USE, WAIT 3 MINUTES BEFORE ATTEMPTING TO RELIGHT THE APPLIANCE.

- 1.6 The appliance is fitted with an oxygen sensitive pilot that will act to cut off the gas supply to the appliance in the event of incorrect operation of the flue. If the system acts to shut off the gas supply, this indicates that there is insufficient flue pull. Continued operation of this safety device means that there may be a serious problem with the flue system, and this should be inspected by a qualified gas engineer. **Do not use the appliance until an engineer says it is safe to do so.** The oxygen sensitive pilot must not be tampered with. Use only genuine Gazco replacement parts when servicing the appliance - refer to Servicing section.



IMPORTANT: REFER TO DATA BADGE AND TECHNICAL SPECIFICATION AT THE FRONT OF THE MANUAL TO ENSURE THE APPLIANCE IS CORRECTLY ADJUSTED FOR THE GAS TYPE AND CATEGORY APPLICABLE IN THE COUNTRY OF USE.

FOR DETAILS OF CHANGING BETWEEN GAS TYPES REFER TO SERVICING, SECTION 13, REPLACING PARTS.

Unpacking

- 1.7 Remove the appliance from its packaging, and check that it is complete and undamaged.

Put the loose ceramic parts to one side so that they are not damaged during installation.

2. Installation of the Appliance

- 2.1 This appliance can be installed in four different ways:
 - 1) Builder's opening with an Edge finish.
 - 2) Builder's opening with a decorative front.
 - 3) Studwork with an Edge finish.
 - 4) Studwork with a decorative front.

Flue Attachment

For additional information please refer to Site Requirements section, page 13.

Options 1 and 2 above can be:

- Top exit with a liner - 5" (127mm)
- Rear exit without a liner - 7" (178mm) minimum

- 2.2 The appliance is supplied with a flue fixing plate to attach the flue liner to the appliance within the aperture.
- 2.3 Locate the flue liner in position and place the flue securing clip over the liner, push the end of the liner over the outside of the spigot and secure by tightening the securing clip, see Diagram 1.

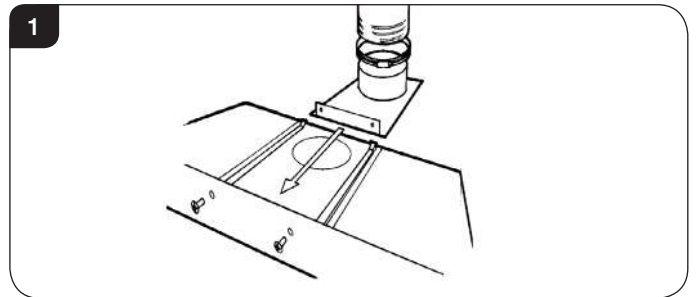

- 2.4 Place the liner in its final position ensuring that the sliding flue plate rests at the correct height in the opening, and that the front flange of the plate rests against the outside face at the top of the opening.
- 2.5 When installing the appliance into a masonry chimney without a liner, it must be converted to a rear exit.
- 2.6 Remove the 2 fixing screws securing the spigot assembly.
- 2.7 Slide the blanking plate into the guides.
- 2.8 Replace the 2 fixing screws, see Diagram 2.

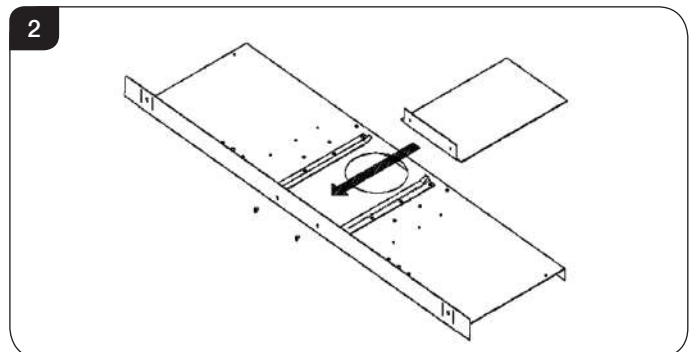

The flue must be in good condition and clear products of combustion, see Installation Instructions, Commissioning.

Installation Instructions

- 2.9 If a flexible liner is to be used check the seal on the inner lip of the spigot plate is intact. Replace if necessary.

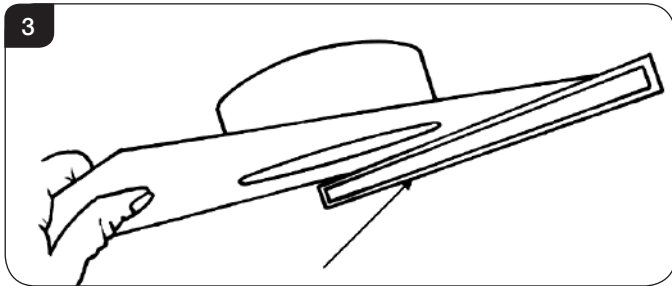

Options 3 and 4 (Studwork with Edge finish or decorative front) must be fitted using the top exit only with rigid twin wall flue pipe.

3. Removing the Glass Frame

- 3.1 Remove the glass door by removing the 2 side trims, see Diagram 4. These are held on by magnets.

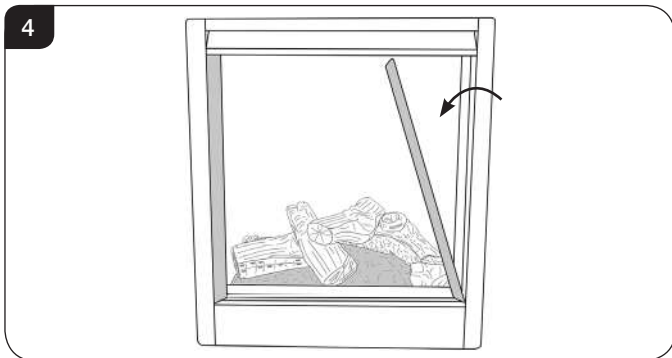

- 3.2 Lift out the bottom slotted trim, see Diagram 5. Note the orientation of the metal shield for reassembly.

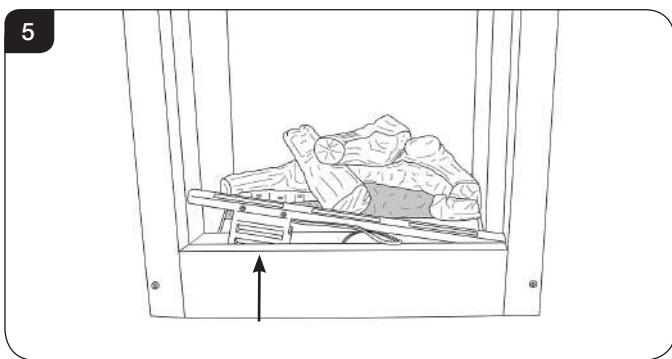

- 3.3 Disconnect the battery lead from the battery pack attached to the lower slotted trim and remove, see Diagram 6.

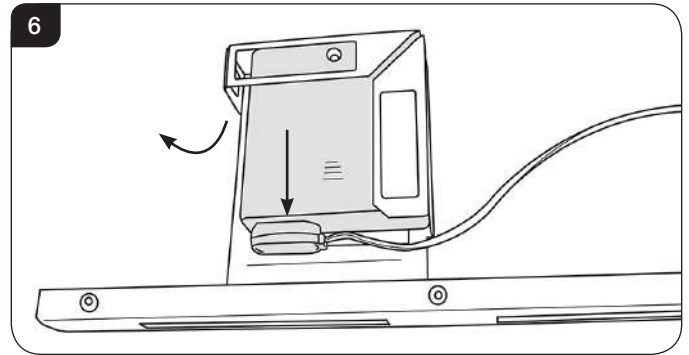

- 3.4 Remove the 2 screws at the base of the door, see Diagram 7.

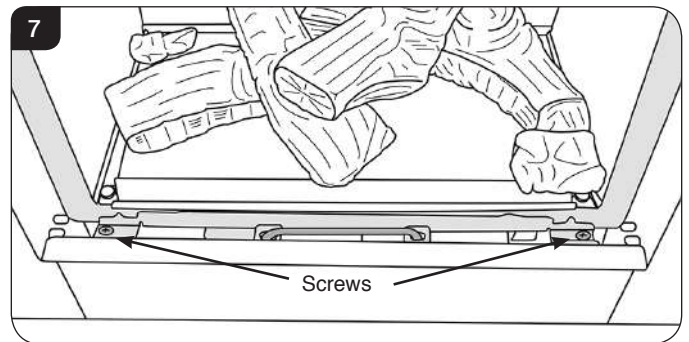

- 3.5 Pull up the handle at the front, see Diagram 8.

- 3.6 Whilst supporting the top, lift the door using the handle, up and over the lower edge, see Diagram 8.

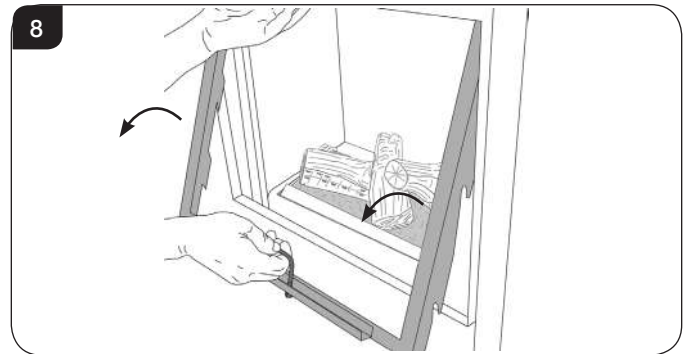

- 3.7 The gas supply enters through the silicone panel located on the left-hand side on the rear of the outer box; this will need to be slit with a sharp knife prior to passing the supply pipe and wall panel cable through, see Diagram 9.

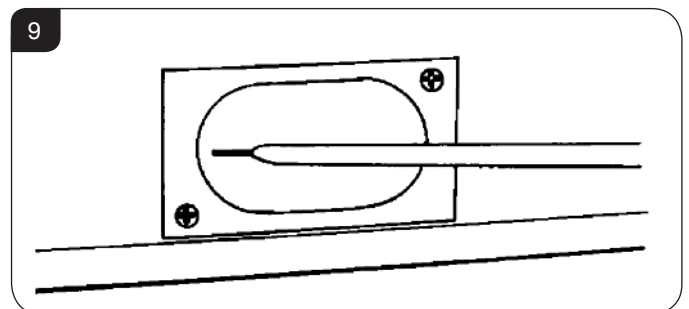

Note: The isolation elbow needs to be attached to the gas pipe before installation.

Installation Instructions

4. Masonry Chimney Installation

4.1 There are 2 methods of installation into a masonry chimney:

4a. Edge finish Installation.

4b. Installation with a decorative front.

Carefully read the relevant section for the installation method required.

4a. Edge Finish Installation

4a.1 This method is designed so that non-combustible board can be taken right up to the edge of the flange of the appliance.

4a.2 Fix the self adhesive foam seal around the back of the fixing flange of the appliance.

4a.3 Prepare the flue connection using the chosen method described in Section 2.

4a.4 Connect the flue and install the appliance into the aperture. At the same time ensure that the gas pipe passes through the silicon panel at the back of the appliance and the wall panel cable passes through the side grommet.

Note: It may be necessary to feed the wall plate cable through the silicon panel during installation.

4a.5 Secure the appliance through the 6 fixing holes using the screws provided, see Diagram 10.

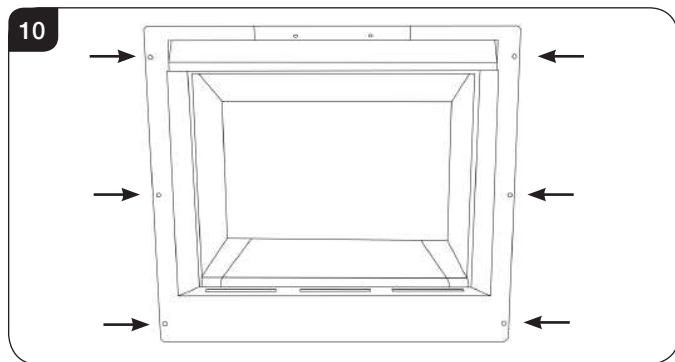

4a.6 Build the chimney breast up to coincide with the edge, allowing for the front to be skimmed level.

4a.7 Fit non-combustible board to the chimney breast around the appliance, using the distance to combustibles detailed in Diagram 11.

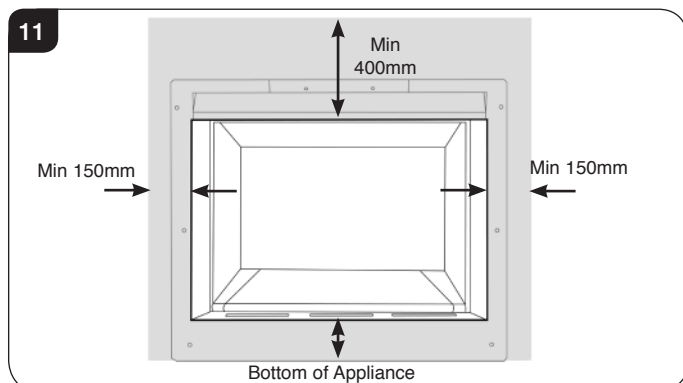

4a.8 Fit plasterboard to the remaining of the chimney breast front.

4a.9 Apply a heat resistant plaster around the appliance using the distance to combustibles detailed in Diagram 11.

4a.10 Apply a plaster finish to remaining chimney breast front.

4b. Installation with a Decorative Front

4b.1 Fix the self adhesive foam seal around the back of the fixing flange of the appliance.

4b.2 Prepare the flue connection using the chosen method described in Section 2.

4b.3 Connect the flue and install the appliance into the aperture. At the same time ensure that the gas pipe passes through the silicon panel at the back of the appliance and the wall panel cable passes through the side grommet.

Note: It may be necessary to feed the wall plate cable through the silicon panel during installation.

4b.4 Secure the appliance through the 6 fixing holes using the screws provided, see Diagram 10.

4b.5 The appliance flange should sit flush to the brickwork and the edge should sit proud of the wall, see Diagram 12.

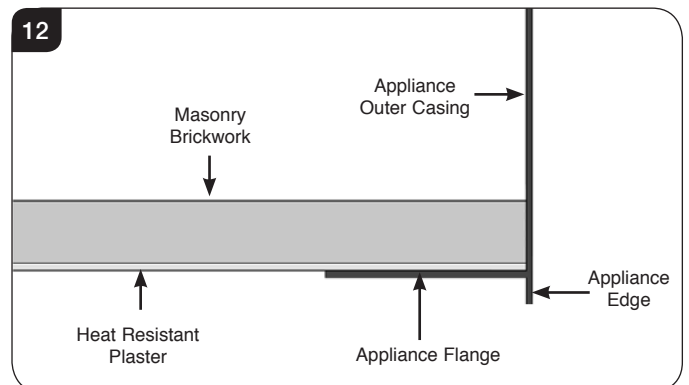

4b.6 The subframe for the decorative front can now be fitted by following the instructions supplied with the Front.

NOTE: THE SUBFRAME MUST SIT FLUSH TO THE WALL LEVEL WITH THE APPLIANCE FLANGE.

Installation Instructions

5. Studwork Installation

5.1 DISTANCE TO COMBUSTIBLE MATERIAL

COMBUSTIBLE PARTS OF THE STUDWORK MUST BE KEPT BEYOND THE MINIMUM DIMENSIONS SHOWN IN DIAGRAM 13.

PROTECT THE NEAREST STUDWORK WITH NON-COMBUSTIBLE MATERIAL AND MAINTAIN THESE DIMENSIONS AT ALL TIMES, SEE DIAGRAM 13.

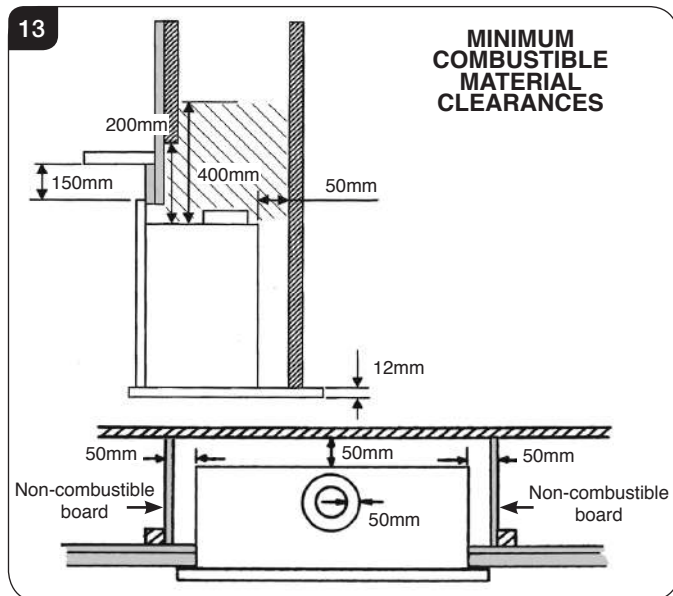

5.2 **DO NOT PACK THE VOID AROUND OR ABOVE THE APPLIANCE WITH INSULATION MATERIALS SUCH AS MINERAL WOOL.**

5.3 **THE VOID BUILT FOR THE CASSETTE MUST BE VENTILATED TO PREVENT A BUILD-UP OF HEAT. IF THE VOID IS SEALED, THEN YOU MUST FIT VENTS AT BOTH LOW AND HIGH LEVELS OF APPROXIMATELY 50CM² EACH. THESE VENTS MUST TAKE COLD AIR FROM THE ROOM AND RETURN WARM AIR BACK INTO THE ROOM.**

5.4 **AN ACCESS HATCH MUST BE LEFT IN THE SIDE OF THE CHIMNEY BREAST FOR FUTURE SERVICING AND INSPECTION OF THE FLUE AND APPLIANCE.**

This installation is Top Exit only. Use only a rigid twin wall flue pipe.

5.5 There are 2 methods of installation into a studwork chimney:

5a. Edge finish Installation.

5b. Installation with a decorative front.

Carefully read the relevant section for the installation method required.

5a. Edge Finish Installation

5a.1 This method is designed so that non-combustible board can be taken right up to the edge of the flange of the appliance.

5a.2 Build the studwork chimney breast and enclosures to the desired size to include the protected platform at the required height.

Ensure that the minimum 50mm distance to combustible studwork is maintained.

5a.3 Line the aperture for the appliance with 12mm thick non-combustible material as shown, see Diagram 14.

Non-combustible board used to protect the studwork can line the aperture inside the 50mm clearance distance, see Diagram 14.

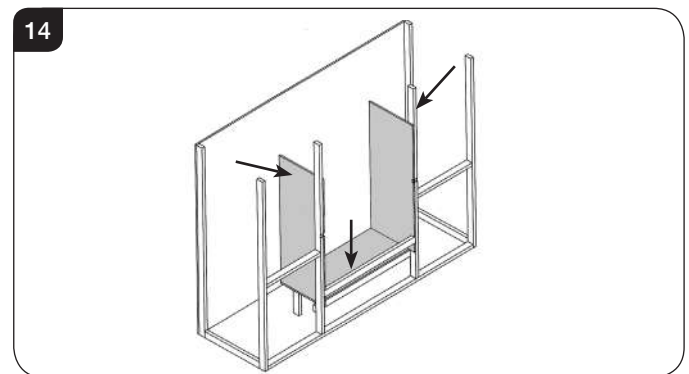

5a.4 Site the appliance and decide on flue requirements.

5a.5 Prepare the flue connection using the chosen method described in Section 2 ensuring that distances to combustible materials are maintained at all times.

Connect the flue and install the appliance into the aperture. At the same time ensure that the gas pipe passes through the silicon panel at the back of the appliance and the wall panel cable passes through the side grommet. Do not secure the appliance at this time.

Note: It may be necessary to feed the wall plate cable through the silicon panel during installation.

5a.6 Fit non-combustible board to the studwork around the aperture. This should extend a minimum of 400mm above the appliance and at least 150mm to the sides of the appliance, see Diagram 15 and Diagram 16.

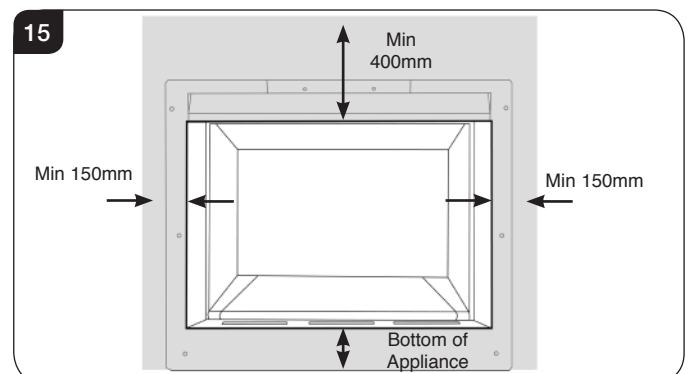

Installation Instructions

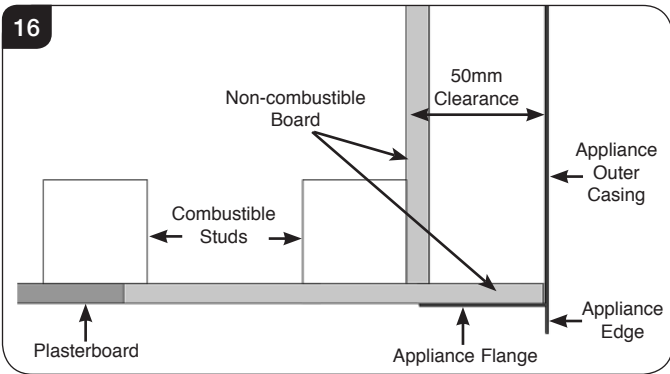

Ensure the clearances are maintained, see Diagram 13.

- 5a.7 Apply plasterboard to the remainder of the studwork.
- 5a.8 Fix the self adhesive foam seal around the back of the fixing flange of the appliance.
- 5a.9 Secure the appliance to the non-combustible board through the 6 fixing holes, using the anchor fixings provided, see Diagram 17 & 18.

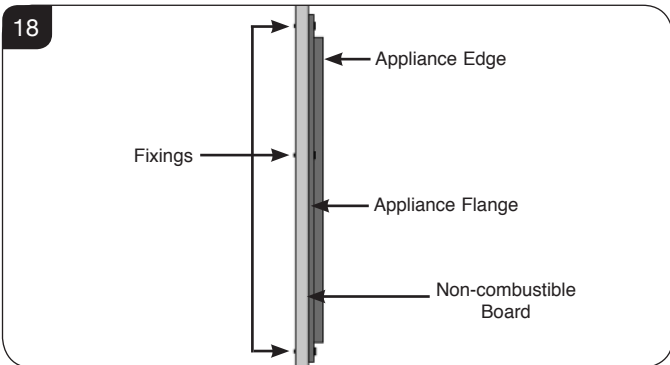
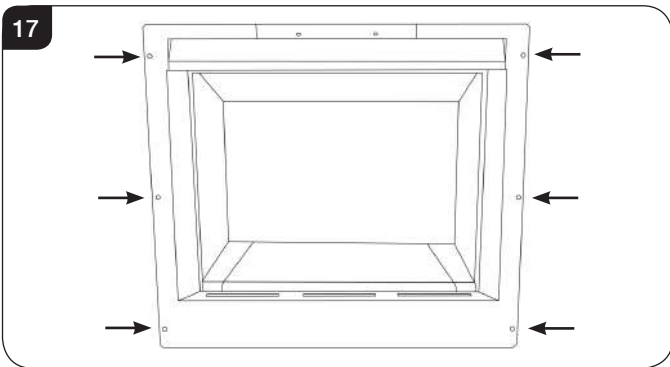

- 5a.10 Fit non-combustible board to the board around the appliance, see Diagram 19. Ensure distances to combustibles are observed, see Diagram 13.

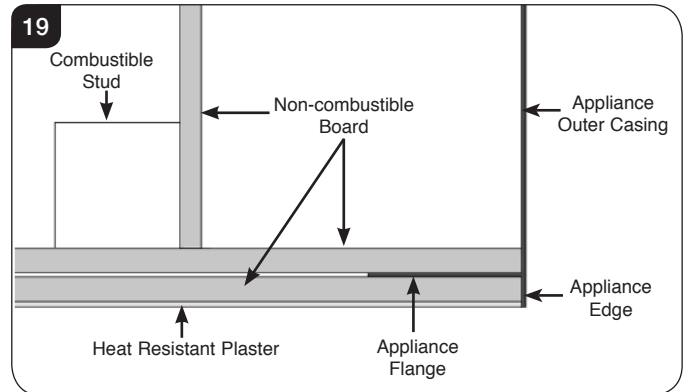

NOTE: If metal studwork is used, there is no need to fit non-combustible board to the face of the construction, see Diagram 20.

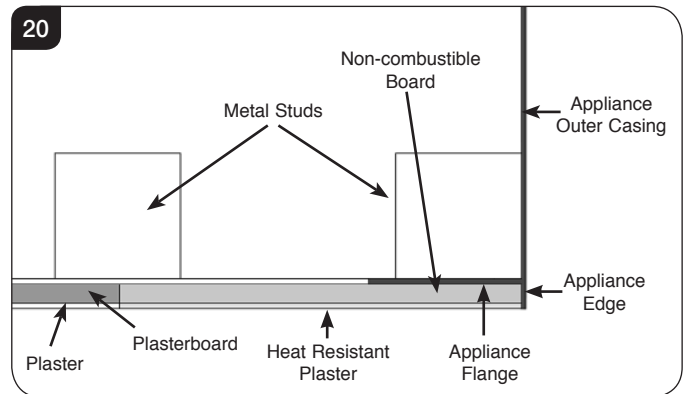

- 5a.11 Apply plasterboard to the remainder of the first layer of plasterboard.
- 5a.12 Apply a heat resistant plaster around the appliance, see Diagram 15. Ensure distances to combustibles are observed, see Diagram 13.
- 5a.13 Apply a plaster finish to the remaining plasterboard.

To finish installation see 5.6.

5b. Installation with a Decorative Front

IMPORTANT: BEFORE THE INSTALLATION OF THE DECORATIVE FRONT ENSURE THAT THE WALL ABOVE AND TO THE SIDES OF THE APPLIANCE IS SUITABLY CONSTRUCTED FOR THE FIXINGS TO SUPPORT THE WEIGHT OF THE FRONT. IF THE WALL IS CONSTRUCTED FROM PLASTERBOARD OR SIMILAR, IT IS ESSENTIAL THAT BATTERNS ARE LOCATED TO THE SIDES OF THE APPLIANCE IN THE FIXING AREA TO PROVIDE STRENGTH TO THE FIXINGS. SEE DIAGRAM 21.

Installation Instructions



Note: When fitting a Gazco Verve XS front refer to the separate instructions to ensure the installation is at the correct height for the chosen finish.

It is essential to read the Gazco Verve XS front instructions thoroughly prior to fitting the appliance as steps need to be incorporated during installation.

- 5b.1 When constructing a studwork installation it is essential to observe the clearances to combustibles but make provision for the frame fixings, see Diagram 21.

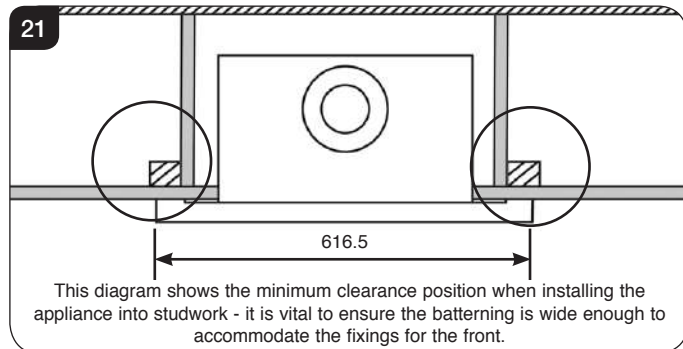

- 5b.2 Build the studwork chimney breast and enclosures to the desired size to include the protected platform at the required height.
- 5b.3 Line the aperture for the appliance with 12mm thick non-combustible material as shown, see Diagram 22.

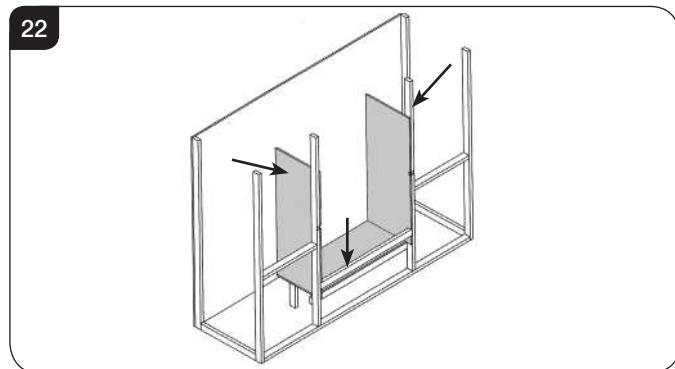

- 5b.4 Site the appliance and decide on flue requirements.
- 5b.5 Prepare the flue connection using the chosen method described in Section 2 ensuring that distances to combustible materials are maintained at all times.

Connect the flue and install the appliance into the aperture. At the same time ensure that the gas pipe passes through the silicon panel at the back of the appliance and the wall panel cable passes through the side grommet. Do not secure the appliance at this time.

Note: It may be necessary to feed the wall plate cable through the silicon panel during installation.

- 5b.6 Fit non-combustible board to the studwork around the aperture. This should extend a minimum of 400mm above the appliance and at least 150mm to the sides of the appliance, see Diagram 23 and Diagram 24.

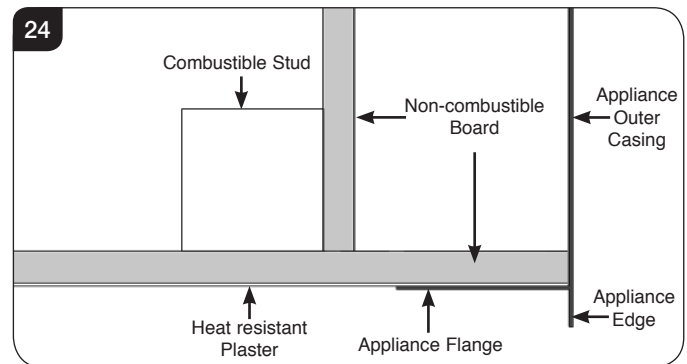
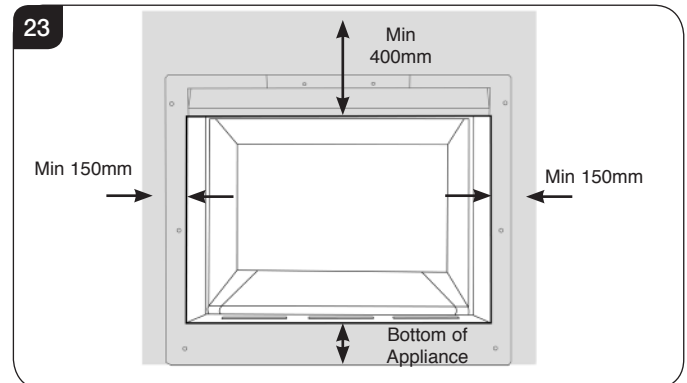

Ensure the clearances are maintained, see Diagram 13.

- 5b.7 Apply plasterboard to the remainder of the studwork and plaster the front face of the board.
- 5b.8 Secure the appliance to the non-combustible board through the 6 fixing holes, using the anchor fixings provided, see Diagram 25 & 26.

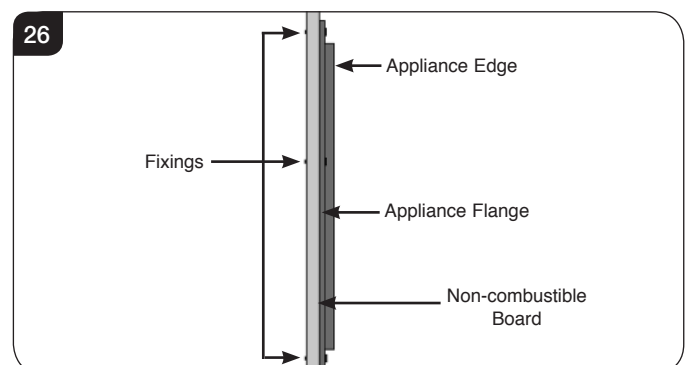
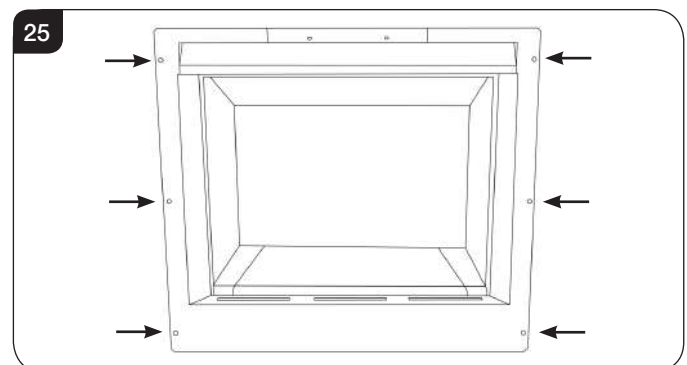

Installation Instructions

- 5b.9 Install the decorative front referring to separate installation instructions.

To finish installation see 5.6.

To Finish the Installation

After commissioning:

- 5.6 Finish the sides of the chimney breast, see Diagram 27.

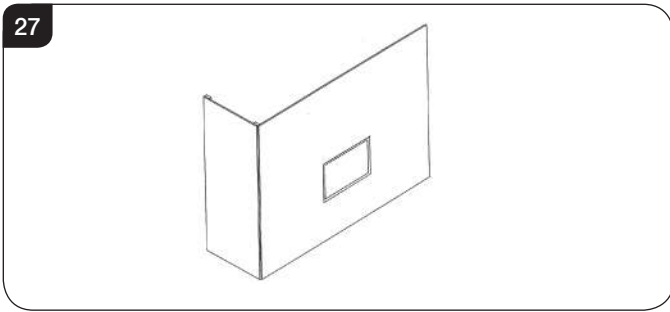

- 5.7 A removable access hatch must be left in the side of the chimney breast for future servicing and inspection of the appliance.

6. Gas Soundness Pressure Check

- 6.1 Connect a suitable pressure gauge to the test point located on the inlet fitting and turn the gas supply on. Light the appliance and check all gas joints for possible leaks. Turn the appliance to maximum and check that the supply pressure is as stated on the databadge. Turn the gas off and replace the test point screw, turn the gas on and check the test point for leaks.

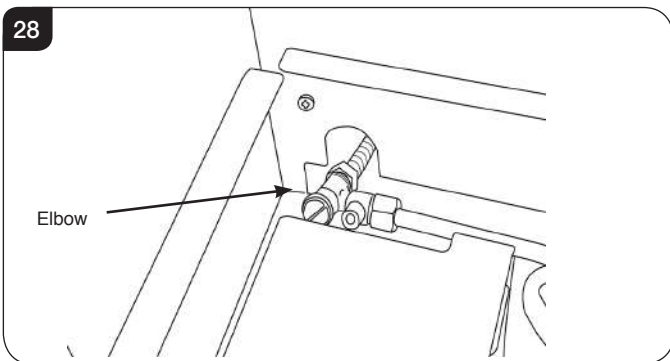

Check the function of the handset, if there is no communication between the remote control and the appliance, see Commissioning Section.

7. Baffle & Liners

LINERS

- 7.1 Angle the rear liner into position carefully, avoiding the bottom bracket and pilot, see Diagram 29.

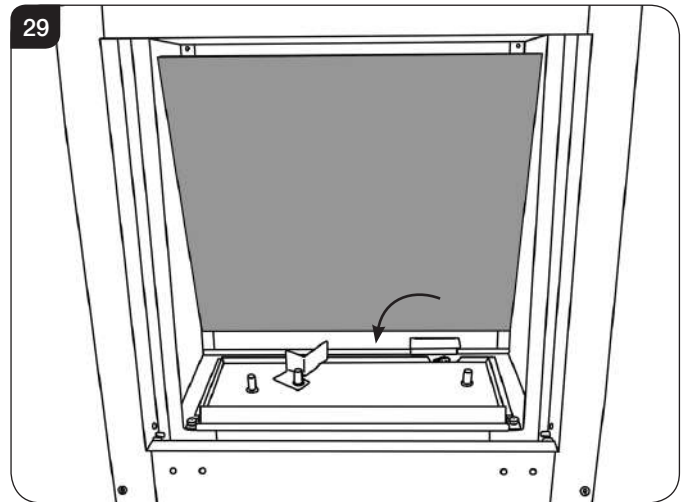

Support the rear liner until the side panels are in place.

VERMICULITE LINERS ONLY:



Ensure the rear panel is fitted in the correct orientation.

If fitted **incorrectly** there will be a **5mm** gap between the top of the liner and the combustion chamber outlet.

If fitted **correctly** there will be a **1mm** gap between the top of the liner and the combustion chamber outlet.

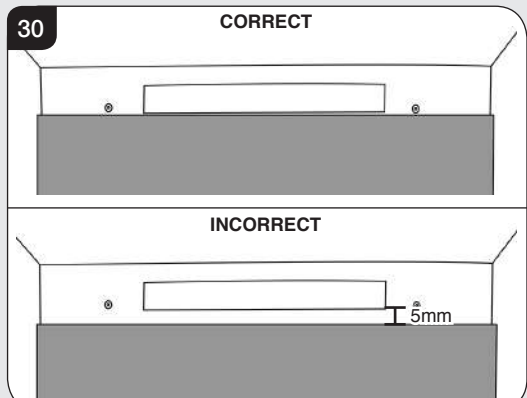

Installation Instructions

- 7.2 Fit the Side liners by placing the bottom edge of the liner on the liner brackets and manoeuvring the bracket into position, see Diagram 31.

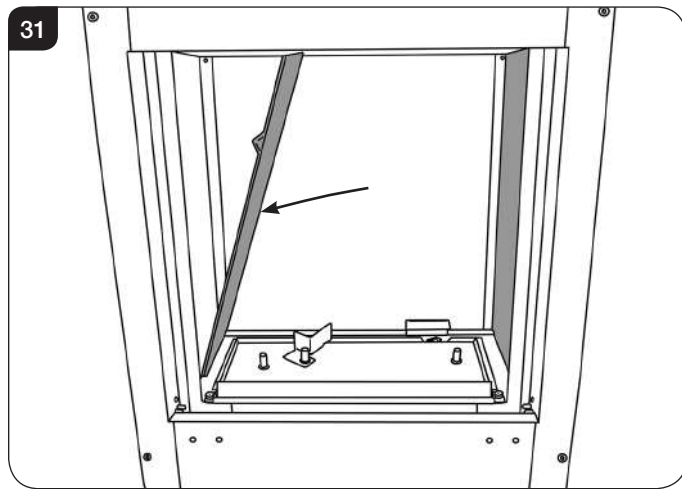

The 2 side liners support the rear liner.

BAFFLE

- 7.3 Position the baffle ensuring the rear edge locates above the rear lip, see Diagram 32.

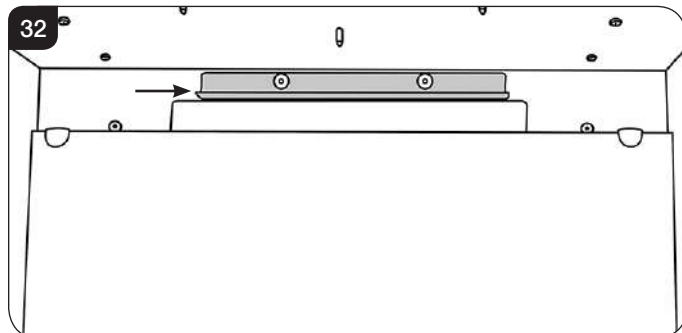

- 7.4 Fasten the 3 screws to secure the baffle to the roof of the firebox, see Diagram 33.

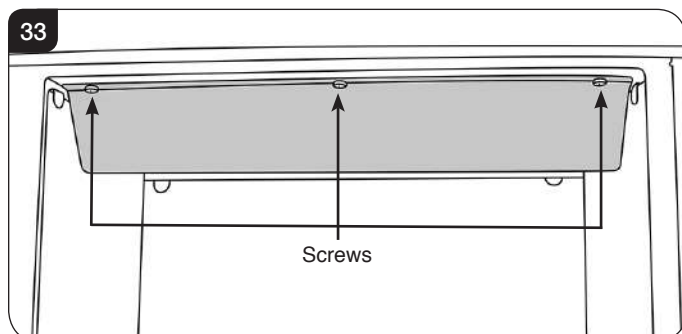

8. Arrangement of Fuel Bed

Advice on handling and disposal of fire ceramics



The fuel effect in this appliance are made from Refractory Ceramic Fibre (RCF), a material which is commonly used for this application.

Protective clothing is not required when handling these articles, but we recommend you follow normal hygiene rules of not smoking, eating or drinking in the work area and always wash your hands before eating or drinking.

To ensure that the release of RCF fibres are kept to a minimum, during installation and servicing a HEPA filtered vacuum is recommended to remove any dust accumulated in and around the appliance before and after working on it. When servicing the appliance it is recommended that the replaced items are not broken up, but are sealed within heavy duty polythene bags and labelled as RCF waste.

RCF waste is classed as stable, non-reactive hazardous waste and may be disposed of at a licensed landfill site.

Excessive exposure to these materials may cause temporary irritation to eyes, skin and respiratory tract; wash hands thoroughly after handling the material.

9. Log Layout

LOGS MUST BE POSITIONED ACCORDING TO THE FOLLOWING INSTRUCTIONS TO GIVE THE CORRECT FLAME EFFECT.

All logs can be identified by a letter (A - D) on their underside. Logs A and B have holes to locate each onto a burner stud.

- 9.1 Ensure the burner tray is clean and free from any debris, see Diagram 34.

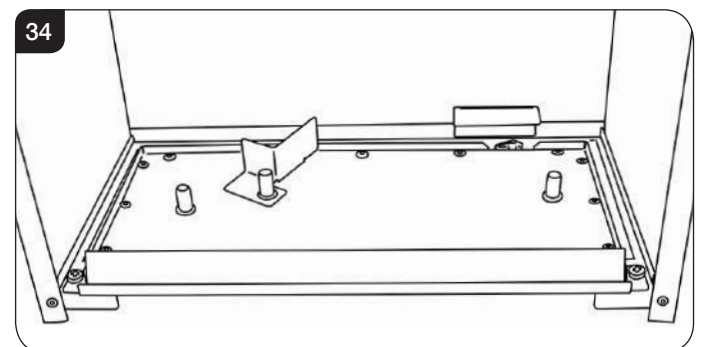

Installation Instructions

- 9.2 Place Log A in position on the 2 locating pins, see Diagram 35.

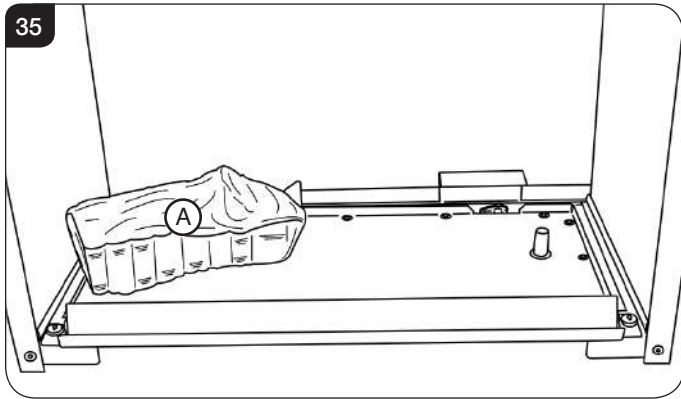

- 9.3 Spread the Lava Rock evenly over the fuel bed and around Log A, see Diagram 36.

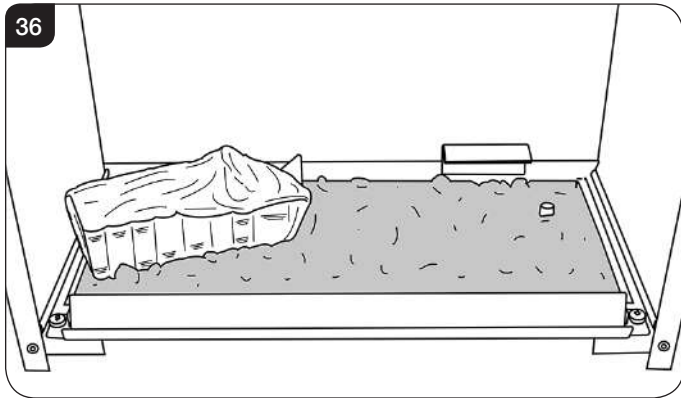

- 9.4 Log B is positioned on the right hand locating pin, and rests against the back liner, see Diagram 37.

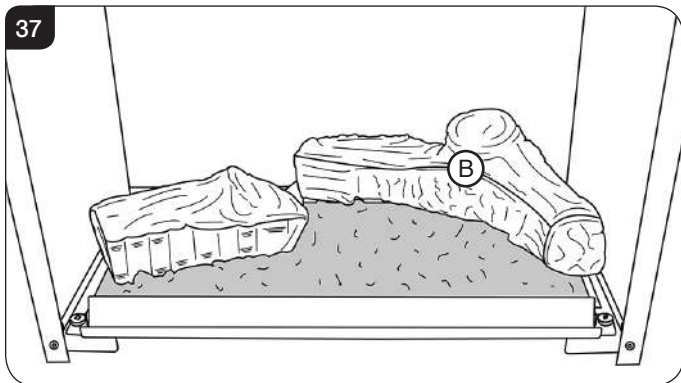

- 9.5 Log C rests on Log A and the front tray with the locating pin facing up, see Diagram 38.

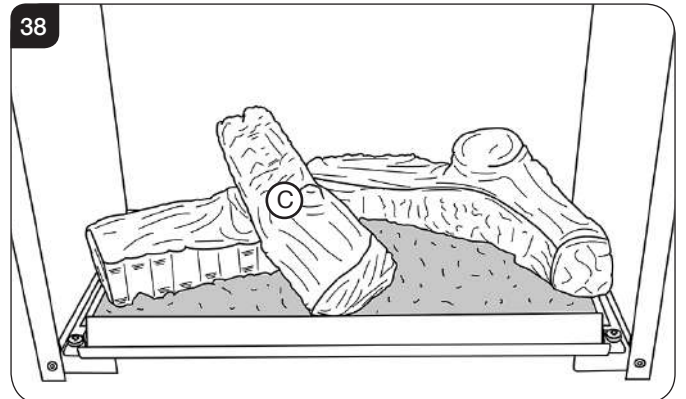

- 9.6 Log D fits onto the locating pin and rests on Log B, see Diagram 39.

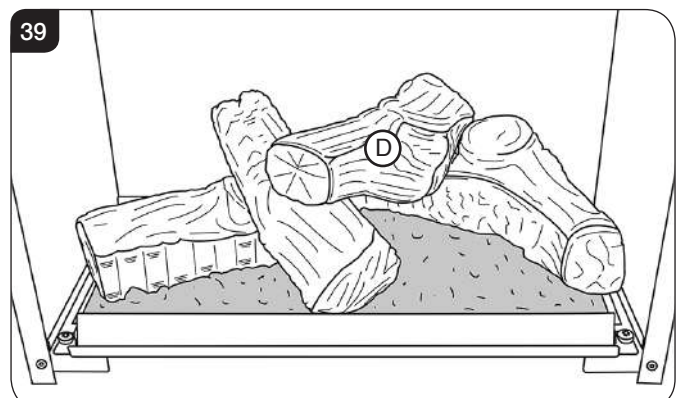

- 9.7 Position the 2 embers in the front right and back left corners, see Diagram 40.

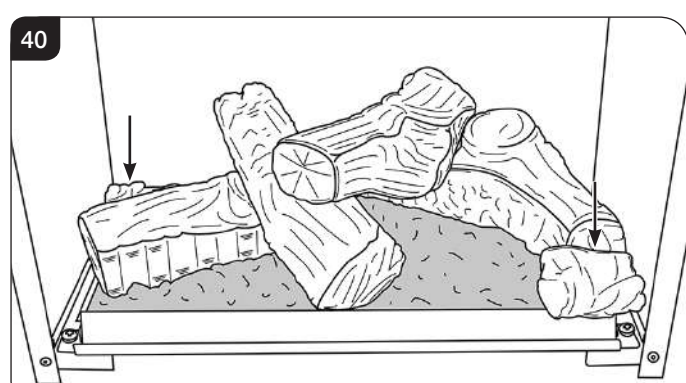

Installation Instructions

- 9.8 Sparingly spread an amount of the Embaglow fibres provided on the sections highlighted, see Diagram 41.
Take care not to use more than half a packet per application.
WARNING - DO NOT PLACE NEAR THE PILOT AREA.

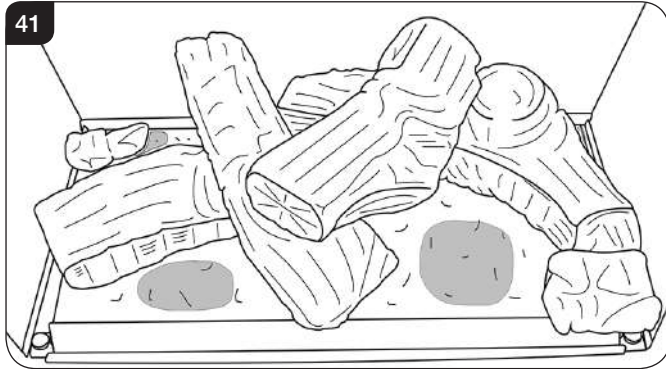

10. Completion of Assembly

Ensure that the fibreglass seal on the back of the glass frame is intact.

- 10.1 To replace the glass frame, position so the hooks on the back of the frame fit over the side pins, see Diagram 42.

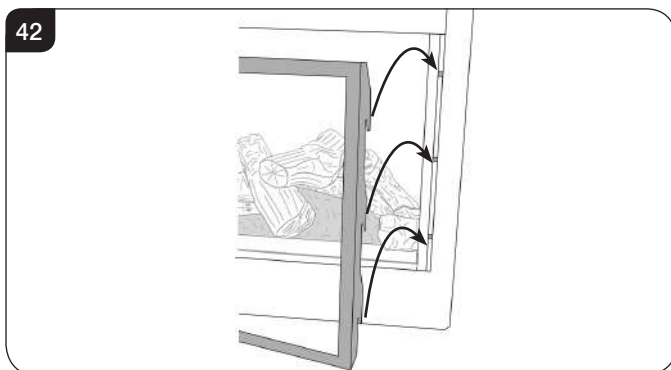

- 10.2 Push the handle down.
- 10.3 Replace the screws. As the screws are tightened the glass frame is pulled down against the hooks and forms a seal.
Replace ALL of the securing screws ensuring that a screw is present in all fixing slots.

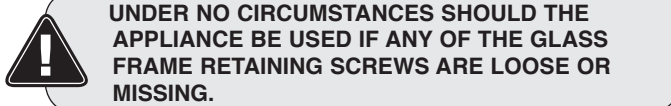

UNDER NO CIRCUMSTANCES SHOULD THE APPLIANCE BE USED IF ANY OF THE GLASS FRAME RETAINING SCREWS ARE LOOSE OR MISSING.

- 10.4 Replace the lower trim, ensuring that the angled metal shield is sloping towards the door frame.
- 10.5 Replace the 2 magnetic side trims.

NEVER OPERATE THE APPLIANCE WHEN THE GLASS PANEL IS REMOVED OR BROKEN.

- 10.6 Replace the decorative front by referring to the separate leaflet supplied with the front.

NOTE: ENSURE THAT THE LOGS ARE POSITIONED AS ABOVE. ONLY USE THE CORRECT AMOUNT OF LOGS AS SPECIFIED IN THE DIAGRAMS.

11. Lighting the Appliance

The appliance is operated by thermostatic remote control.



This remote controls the appliance from pilot ignition through to shut down.

In 'MANUAL MODE' you can:

- light the pilot
- turn on the main burner
- regulate the flame from low to high and back
- turn off the burner leaving just the pilot burning

In 'TEMP MODE' you can:

- set the room temperature so the stove automatically maintains that temperature

In 'TIMER MODE' the appliance:

- turns on and off according to the set time periods
- automatically regulates the room temperature during the set periods

11.1 Turning the appliance On

Your remote can control the gas appliance from pilot ignition through to shut down.

To turn the appliance on press the OFF button and the UP button simultaneously. You hear several short signals.

The pilot and main burner ignite and the remote is now in Manual Mode:

Turning the appliance Off:

Press the OFF button to turn the appliance off.
FOR SAFETY, YOU MUST WAIT 30 SECONDS BEFORE LIGHTING THE APPLIANCE AGAIN.



IMPORTANT: YELLOW FLAMES TYPICALLY APPEAR WHEN THE APPLIANCE HAS REACHED NORMAL OPERATING TEMPERATURE. THIS CAN TAKE UP TO 30 MINUTES.



WARNING: IF THE APPLIANCE FAILS TO LIGHT OR BECOMES EXTINGUISHED IN USE, WAIT 3 MINUTES BEFORE ATTEMPTING TO RELIGHT.

FOR FULL OPERATING INSTRUCTIONS AND TROUBLESHOOTING SEE USER SECTION.

Commissioning

1. Commissioning

- 1.1 Check the flame picture, log layout.
- 1.2 Check the gas pressure.
- 1.3 Close all door and windows in the room.
- 1.4 Ignite the Riva2 and operate on maximum for 5 minutes.
- 1.5 Position a lighted smoke match just inside the draught diverter opening (under the canopy) and check all smoke is drawn in along the opening, see Diagram 1.

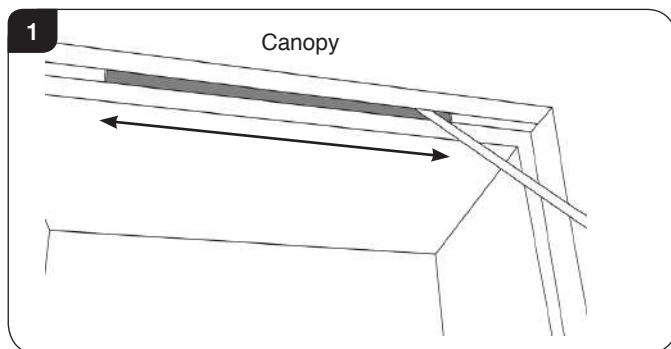

If there is any doubt:

- 1.6 Run the appliance for a further 10 minutes and repeat the test.
- 1.7 Complete the Commissioning Checklist at the front of this manual covering:
 - Thermocouple soundness checks.
This is to include ensuring the thermocouple is secure on the pilot bracket assembly, lead connection and integrity.
 - Flue checks
 - Gas checks
 - Log/fuel effect layout - flame picture

For working pressure test, refer to Installation Instructions Section 6.

- 1.8 Upon completion of the commissioning and testing of the installation and correct operation of the appliance, the installer must instruct the user how to operate the appliance.

- 1.9 Guide the user through the User Instructions paying particular attention to:
 - a) Regular servicing (Section 10 of the User Instructions).
 - b) Ventilation (Section 11 of the User Instructions) - point out the ventilation positions where applicable.
 - c) Hot surfaces (Section 13 of the User Instructions).
 - d) How the appliance works with the remote control handset and the modes of operation (Section 2 of the User Instructions).
 - e) How to change settings in the auto mode and program modes of operation.
 - f) What to do if the appliance fails to operate (Section 14 of the User Instructions).

If there are any extractor fans in the room or adjacent rooms, the test must be repeated with the fans running on maximum.

IF SPILLAGE PERSISTS, DISCONNECT THE APPLIANCE AND SEEK EXPERT ADVICE.

For future reference, record the installation details on the Commissioning Sheet on page 3.

Reprogramming handset/Control box

To access the control box see Servicing Instructions, Section 4 - Main Burner.

- Press and hold the reset button on the control box until you hear two signals. After the second longer signal:
- Release the reset button and within 20 seconds:
- Press the DOWN button on the handset until you hear two additional short signals confirming the new code is set.
If there is a single long signal the code learning sequence has failed or the wiring is incorrect.

Servicing Instructions

Servicing/Fault Finding Charts

1. Servicing Requirements

IMPORTANT – The glass panel on this appliance should be checked for any signs of damage on the front face of the glass panel (scratches, scores, cracks or other surface defects). If damage is observed, the glass panel must be replaced and the appliance must not be used until a replacement is installed. Under no circumstances should the appliance be used if any damage is observed. Please isolate the appliance until a replacement glass panel has been obtained and installed. Replacement glass panels can be purchased from Gazco via the retailer from which the appliance was purchased or any other Gazco distributor.

This appliance must be serviced at least once a year by a competent person.

All tests must be carried out in accordance with the current GasSafe recommendations.

1.1 Before Testing:

- Conduct a gas soundness test for the property ensuring there are no leaks before servicing.
- Check the operation of the appliance before testing.

1.2 Special checks:

- Clean the burner using a vacuum cleaner with a soft brush attachment. Ensure all debris is removed from the burner ports.
- Clean away lint or fluff from the pilot.

- Clean away lint or fluff from under the burner.
- Check the spark gap on the pilot is correct.
- Ensure that the glass frame is secured correctly and that all retaining screws are in place.

1.3 Correct any faults found during the initial test.

1.4 Re-commission the appliance in accordance with Commissioning Procedures of these instructions.

1.5 Advise the customer of any remedial work undertaken.

REPLACE BATTERIES BEFORE ATTEMPTING TO RECTIFY ANY FAULTS.

ELECTRONIC CONTROL VALVE FAULT ANALYSIS

Symptom	Cause	Remedy
Frequent beeps for 3 seconds after operation request	Batteries low in appliance	Replace appliance batteries
No ignition, 5 second continuous tone (there may be several short beeps before)	Loose/damaged wire	Check interrupter block and wires
No ignition, no tone, motor turns slightly when operated	Receiver board damaged	Replace receiver
No pilot flame and control continues to spark	Thermocouple circuit wired incorrectly	Correct wiring
Pilot lights, control continues to spark, valve shuts down after 10 - 30 seconds	1. Loose/damaged wires 2. Receiver board damaged	1. Check interrupter and wires 2. Replace receiver

IGNITION FUNCTIONAL CHECK 1

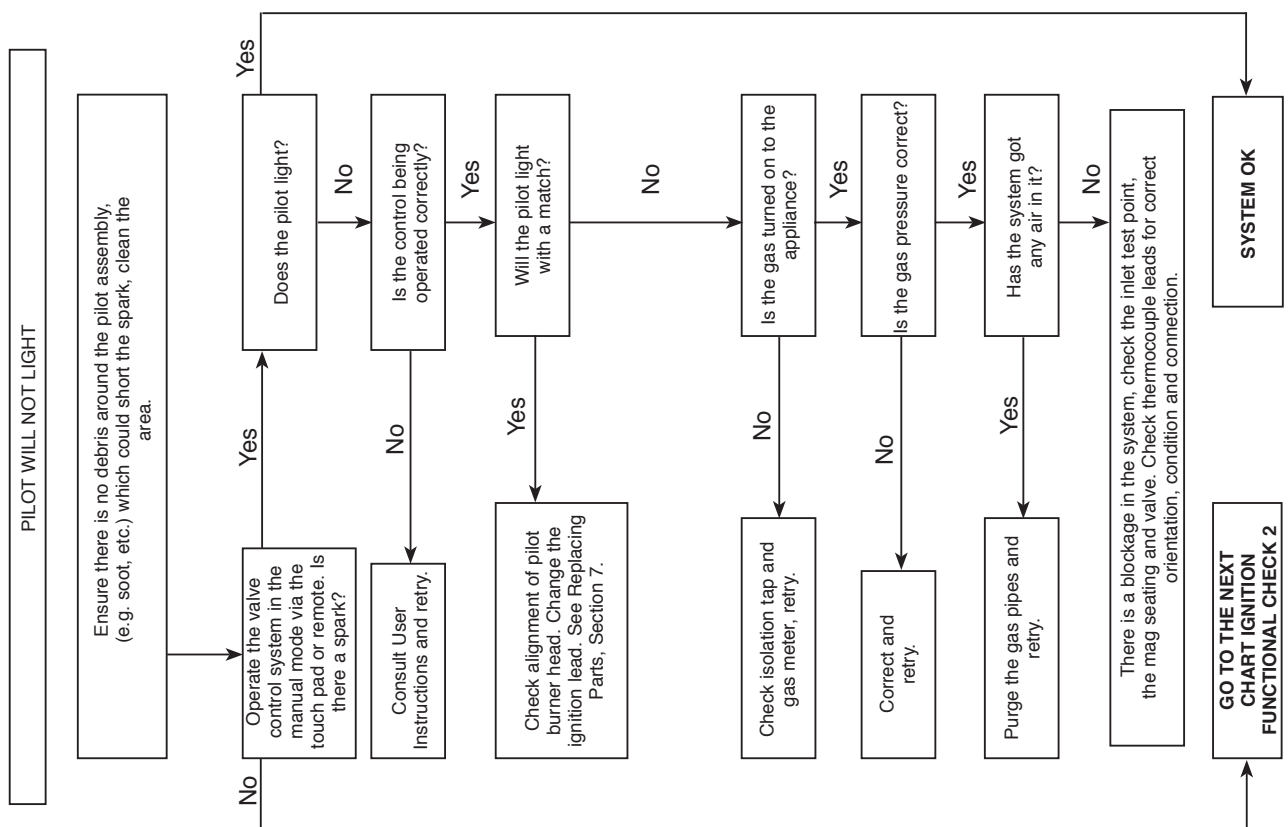

Servicing Instructions

Fault Finding Charts

FLAME FAILURE FUNCTIONAL CHECK 3

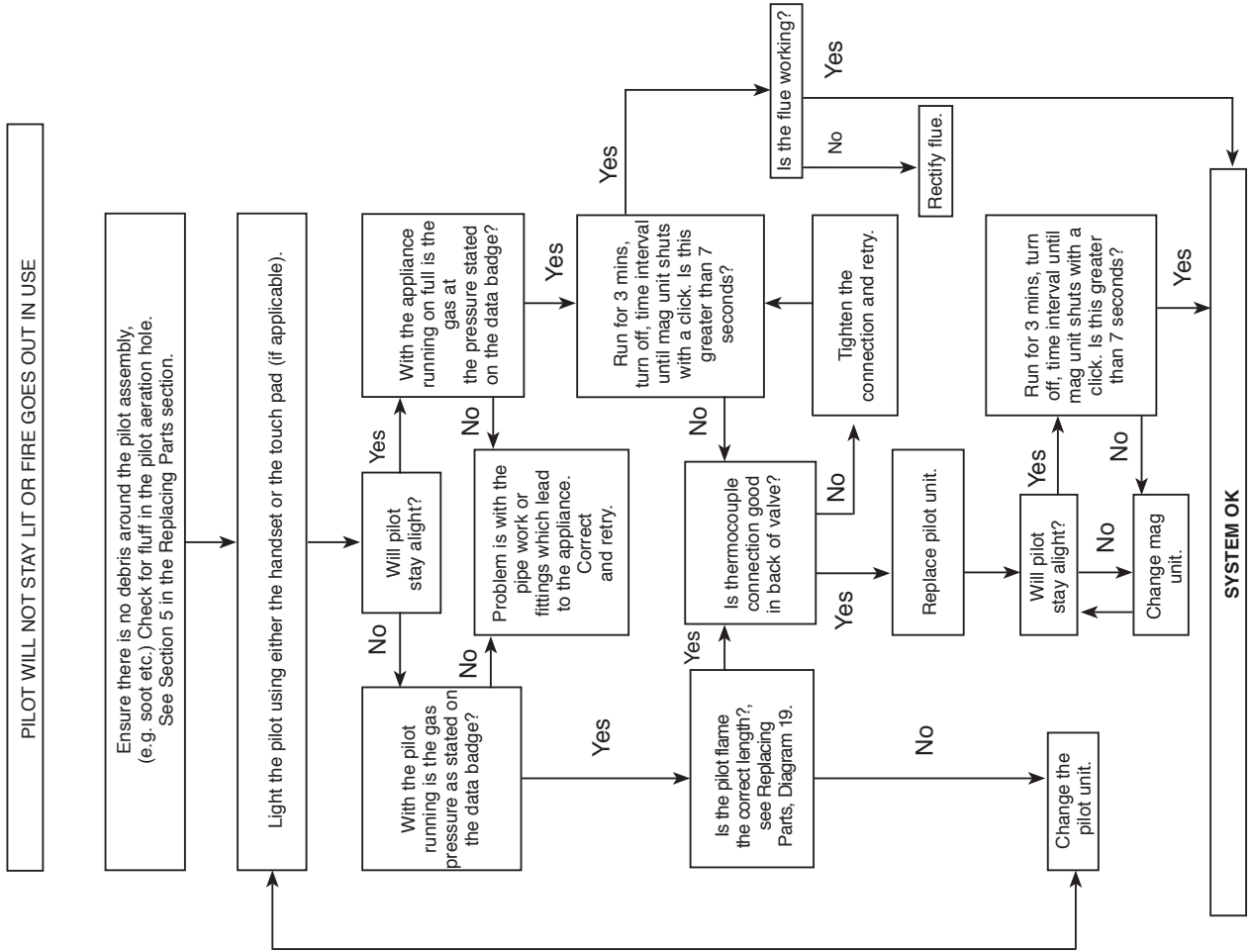

IGNITION FUNCTIONAL CHECK 2

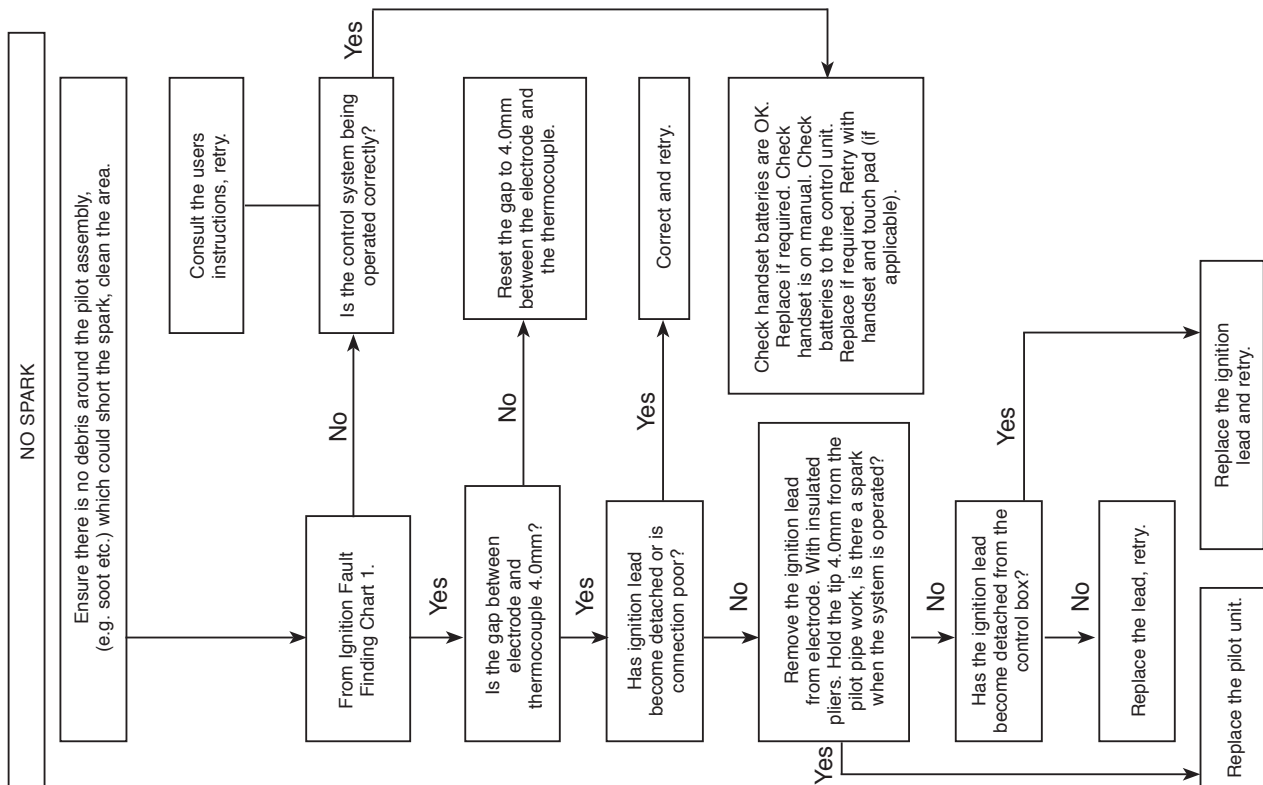

Servicing Instructions - Replacing Parts

1. General

- 1.1 All main components can be replaced without removing the appliance from its installation.

IT IS ESSENTIAL THAT THE GAS SUPPLY TO THE APPLIANCE IS TURNED OFF AT THE ISOLATION DEVICE BEFORE PROCEEDING FURTHER.

- 1.2 It will be necessary to remove the complete burner module before any of the components can be serviced.

2. Removing the Glass Frame

- 2.1 Remove the glass frame by removing the 2 side trims, see Diagram 1. These are held on by magnets.

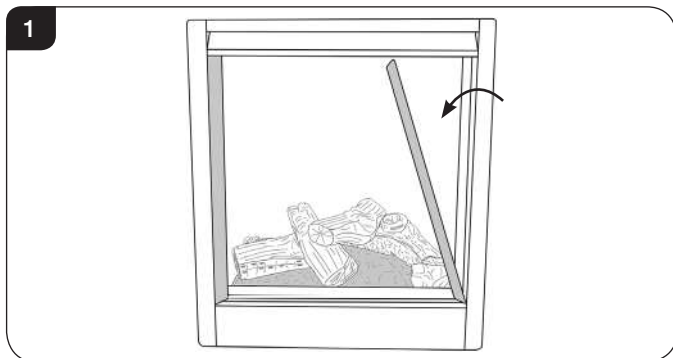

- 2.2 Lift out the bottom slotted trim, see Diagram 2. Note the orientation of the metal shield for reassembly.

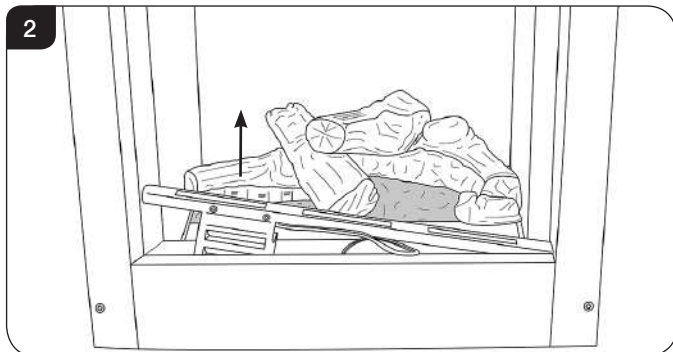

- 2.3 Disconnect the battery lead from the battery pack attached to the lower slotted trim and remove, see Diagram 3.

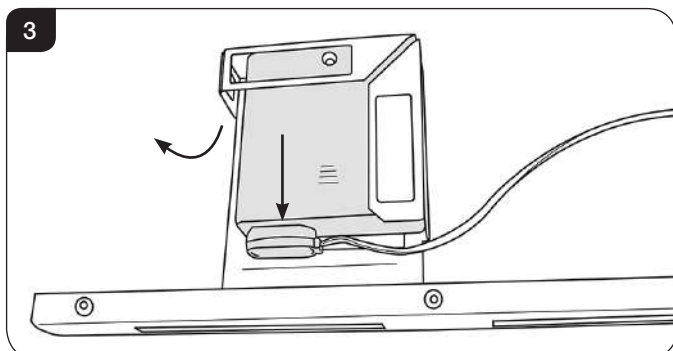

- 2.4 Remove the 2 screws at the base of the door, see Diagram 4.

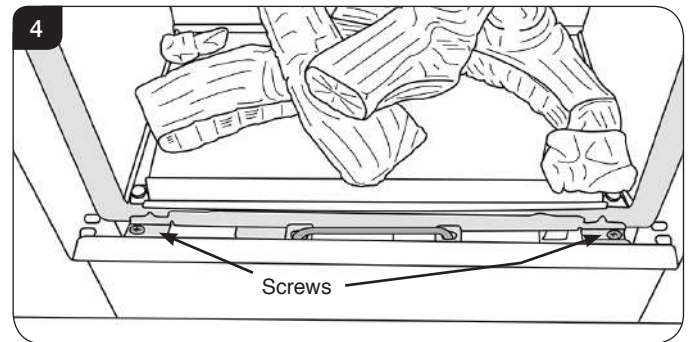

- 2.5 Pull up the handle at the front, see Diagram 4.

- 2.6 Whilst supporting the top, lift the door using the handle up and over the lower edge, see Diagram 5.



- 2.7 Remove the logs, and place them on a dry, clean surface.

When refitting the glass frame ensure that the fibreglass seal on the back of the frame is intact.

- 2.8 To replace the glass frame, position so the hooks on the back of the frame fit over the side pins, see Diagram 4.

- 2.9 Push the handle down.

- 2.10 Replace the screws. As the screws are tightened the glass frame is pulled down against the hooks and forms a seal. **Replace ALL of the securing screws ensuring that a screw is present in all fixing slots.**

! UNDER NO CIRCUMSTANCES SHOULD THE APPLIANCE BE USED IF ANY OF THE GLASS FRAME RETAINING SCREWS ARE LOOSE OR MISSING.

- 2.11 Replace the lower trim, ensuring that the angled metal shield is sloping towards the door frame.

- 2.12 Replace the 2 magnetic side trims.

NEVER OPERATE THE APPLIANCE WHEN THE GLASS PANEL IS REMOVED OR BROKEN.

- 2.13 The glass front must be refitted to the appliance following cleaning or servicing.

Servicing Instructions - Replacing Parts

3. Baffle & Liners

- 3.1 To access the burner tray and interior workings of the appliance it is necessary to remove the baffle and the liners.

BAFFLE

The baffle must be removed before the liners can be taken out of the appliance.

- 3.2 To do this undo the 3 screws securing it to the roof of the firebox, see Diagram 6.

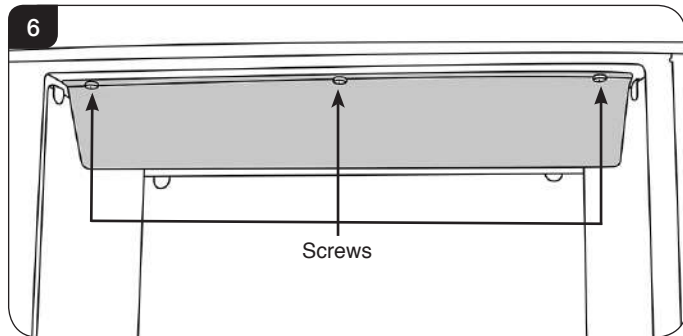

- 3.3 The baffle can now be removed by lowering the front edge and pulling forward through the front of the appliance. **TAKE CARE NOT TO DAMAGE THE SIDE PANELS.**

- 3.4 Note: When replacing the baffle ensure that the rear edge locates above the rear lip, see Diagram 7.

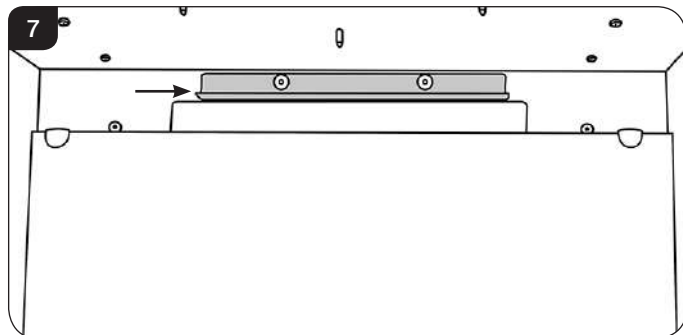

LINERS

Once the baffle and logs have been placed carefully to one side the liners can then be taken out in the following order.

- 3.5 To remove the Right Hand liner first tilt inwards towards the centre of the firebox before lifting up and pulling out through the front of the firebox, see Diagram 8.

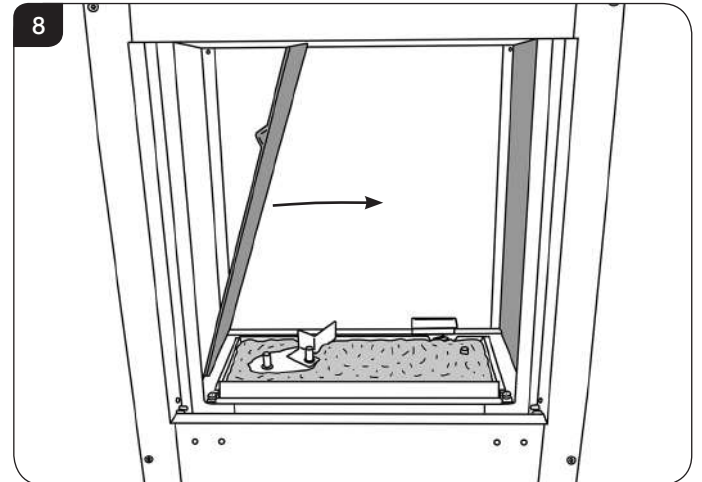

- 3.6 To remove the Left Hand liner first tilt inwards towards the centre of the firebox before lifting up and pulling out through the front of the firebox, see Diagram 9.

The 2 side liners also support the rear liner. Taking out the side liners will allow the rear liner to drop down so ensure it is supported.

- 3.7 Remove the back liner by carefully lifting over the bottom bracket and twisting slightly to allow it to be removed through the front of the appliance, see Diagram 9.

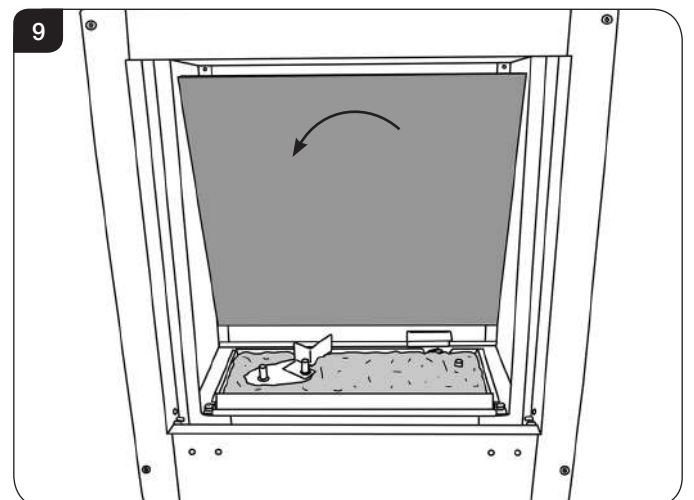

Servicing Instructions - Replacing Parts

- 3.8 With the liners and baffle removed the firebox is clear for cleaning and maintenance, see Diagram 10.

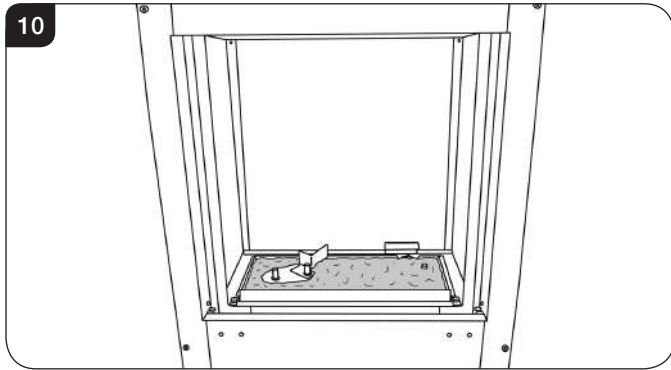

- 3.9 To replace the liners and baffle reverse these procedures.

4. Main Burner

- 4.1 To remove the frame from the appliance please refer to the separate instructions supplied with the frame.
- 4.2 Remove the glass frame, see Section 2.
- 4.3 Remove the baffle and vermiculite liners, see Section 3.
- 4.4 Remove the two screws securing the front deflector plate and carefully slide off the burner tray, see Diagram 11. Ensure the lip locates under the burner tray when replacing.

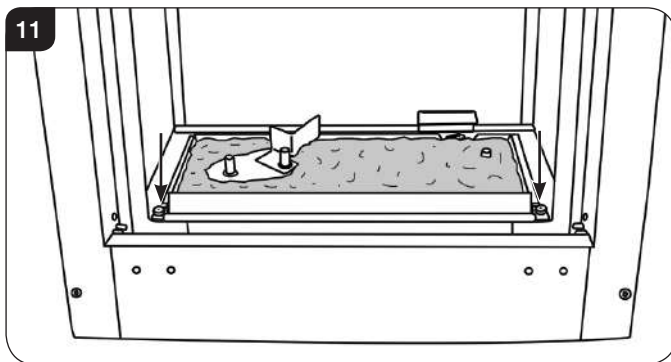

- 4.5 Remove the 2 screws at the front of the burner tray, see Diagram 12.
TAKE CARE NOT TO DAMAGE THE FUELBED WHEN REMOVING THE SCREWS.

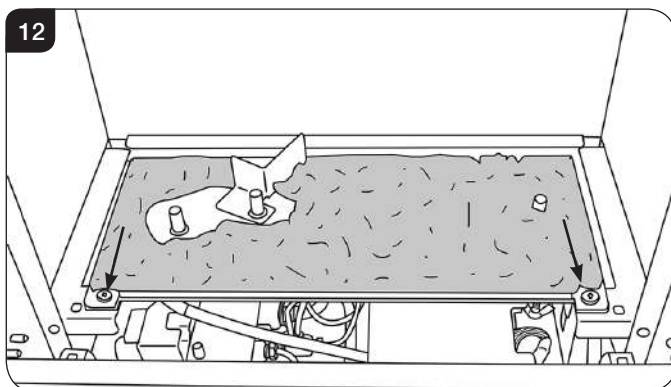

Note: At the same time as removing of the Main Burner the battery supply cable must be carefully disconnected from the control box.

- 4.6 Slide the burner to the left and lift carefully to remove.

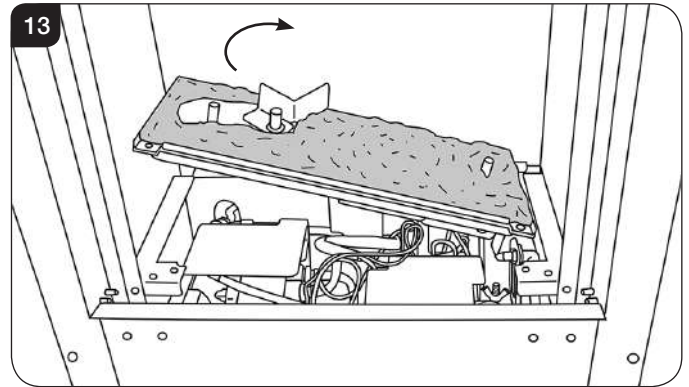

- 4.7 As the Main Burner is removed, carefully disconnect the battery supply cable a from the control box.
- 4.8 Turn the gas supply off at the isolation device.

HAVE YOU ISOLATED THE GAS SUPPLY?

- 4.9 Disconnect the isolating device from the appliance inlet pipe to isolate the gas supply, see Diagram 14.

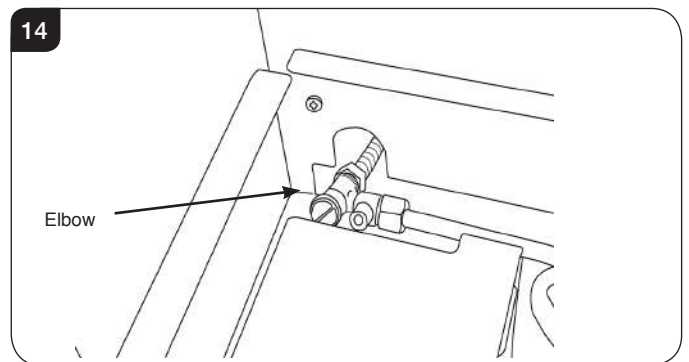

The burner unit can now be serviced.



NOTE: When replacing the Burner Unit ensure the ropeseal on the rear edge is intact. Replace if it is damaged or showing signs of wear.

Servicing Instructions - Replacing Parts

5. Control Assembly

5.1 Turn the gas supply off at the isolation device.

HAVE YOU ISOLATED THE GAS SUPPLY?

5.2 Disconnect the isolating device from the appliance inlet pipe to isolate the gas supply, see Diagram 14.

5.3 Remove the main burner, see Section 4.

5.4 Remove the 2 wingnuts from the base of the Control Assembly, see Diagram 15.

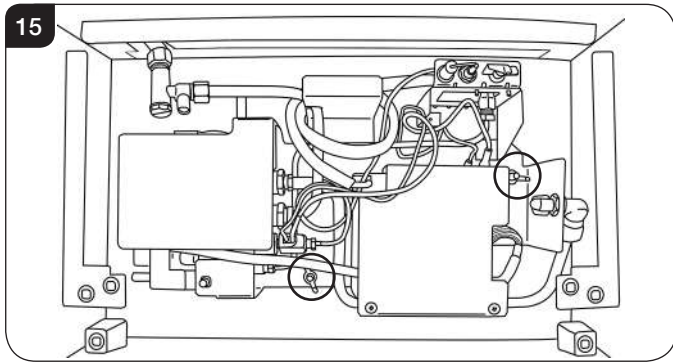

5.5 Lift and remove the Control Assembly, see Diagram 16.

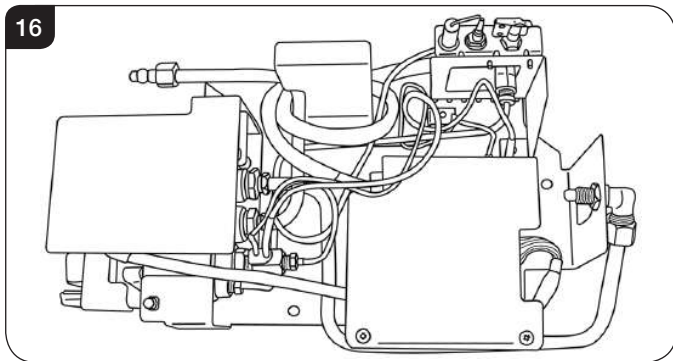

The individual components can now serviced.

6. Pilot Assembly

6.1 Remove the Main Burner and Control Assembly as described in Servicing, Replacing Parts, Sections 4 & 5.



IMPORTANT: UNDER THE TERMS OF THE EXTENDED WARRANTY IT WILL BE COMPULSORY TO CHANGE THE COMPLETE PILOT UNIT ON THIS APPLIANCE IN YEARS 2 AND 4.

6.2 Undo the 2 screws & compression nut to remove the pilot shield, see Diagram 14.

6.3 Remove the ignition lead from the electrode, see Diagram 17.

6.4 Undo the 2 retaining screws from pilot unit bracket, see Diagram 17.

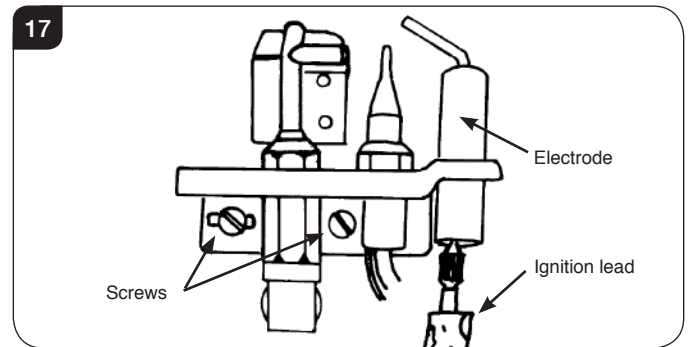

6.5 Undo the thermocouple nut from the interrupter block at the rear of the gas valve, see Diagram 18.

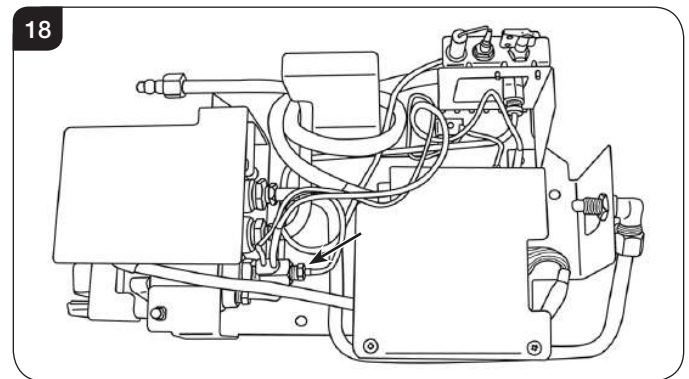

6.6 When replacing the pilot ensure the thermocouple follows its original route.

Servicing Instructions - Replacing Parts

- 6.7 Set the spark gap, see Diagram 19.

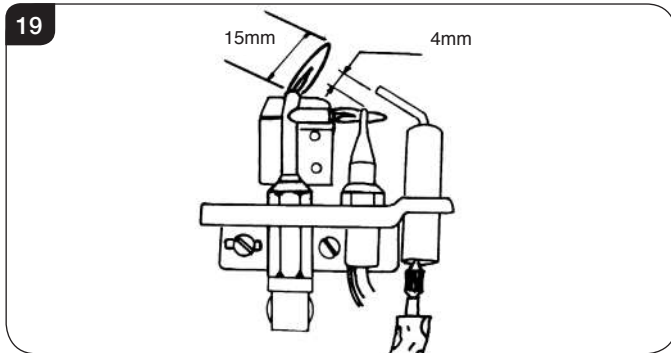

7. Ignition Lead

- 7.1 Remove the Main Burner and Control Assembly as described in Servicing, Replacing Parts, Sections 4 & 5.
- 7.2 Undo the 2 screws & compression nut to remove the pilot shield.
- 7.3 Disconnect the ignition lead from the electrode and from the control box, see Diagram 20.

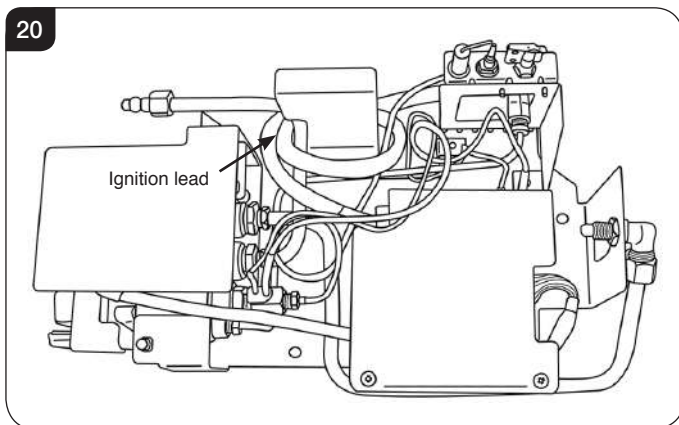

- 7.4 Replace with a new ignition lead following the original route. Refit the Vidaflex cover over the lead. Ensure the cover engages fully over the electrode.
- 7.5 Check the operation of the new ignition lead.
- 7.6 Replace the pilot shield.

8. Gas Valve

- 8.1 Remove the Main Burner and Control Assembly as described in Servicing, Replacing Parts, Sections 4 & 5.
- To change the gas valve:
- 8.2 Disconnect the gas inlet pipe, see Diagram 21, Arrow A.
- 8.3 Disconnect the gas outlet pipe, see Diagram 21, Arrow B.
- 8.4 Disconnect the pilot pipe, see Diagram 21, Arrow C.
- 8.5 Disconnect the thermocouple, thermocurrent wires and the interrupter block, see Diagram 21, Arrow D.

- 8.6 Remove the eight wire loom, see Diagram 21, Arrow E.

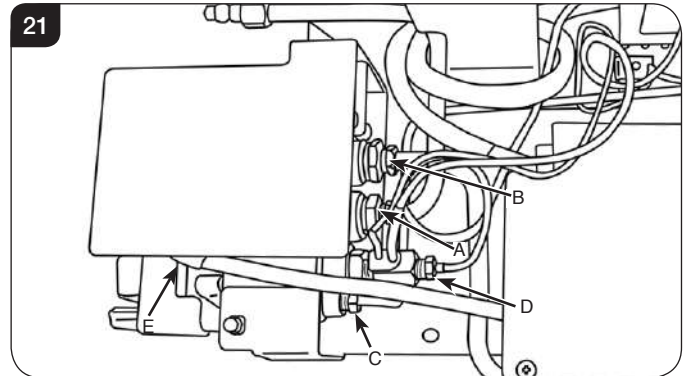

- 8.7 Remove the 2 screws securing the valve from the underside of the Control Assembly and withdraw the valve, see Diagram 22.

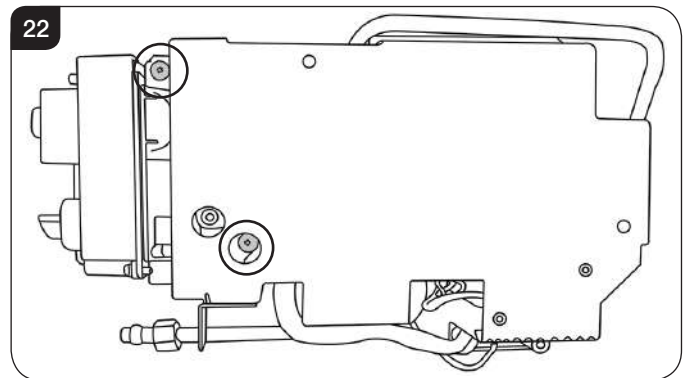

Replace in reverse order and check for leaks.

9. Magnetic Safety Valve

- 9.1 Remove the Main Burner and Control Assembly as described in Servicing, Replacing Parts, Sections 4 & 5.
- 9.2 Turn the burner over and place on a soft surface so as to not damage the unit.
- 9.3 Undo the thermocouple from the interrupter block and remove the two interrupter leads.
- 9.4 Unscrew the interrupter block from the back of the valve.
- 9.5 Undo the silver magnetic valve retaining nut on the back of the valve.
- 9.6 Gently tap out the mag valve.
- 9.7 Replace with a new unit.
- 9.8 Reassemble in reverse order ensuring that the interrupter leads are connected correctly with the blue tag lead furthest away from the gas valve body.
- 9.9 Check for leaks.

Servicing Instructions - Replacing Parts

10. Control Box

- 10.1 Remove the two screws securing the Control Box heat shield and lift away, see Diagram 23.

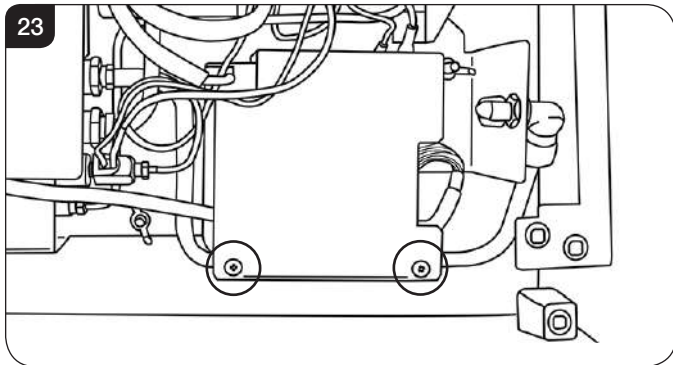

- 10.2 Remove the two thermocurrent cables by removing the two screws, see Diagram 24.
 10.3 Remove the ignition lead, see Diagram 24.
 10.4 Remove the eight wire loom from the control box.
 10.5 Remove the battery extension cable, see Diagram 24.

The control box can now be replaced.

When replacing the sealing plate on the rear of the control cover use a suitable silicone sealant.

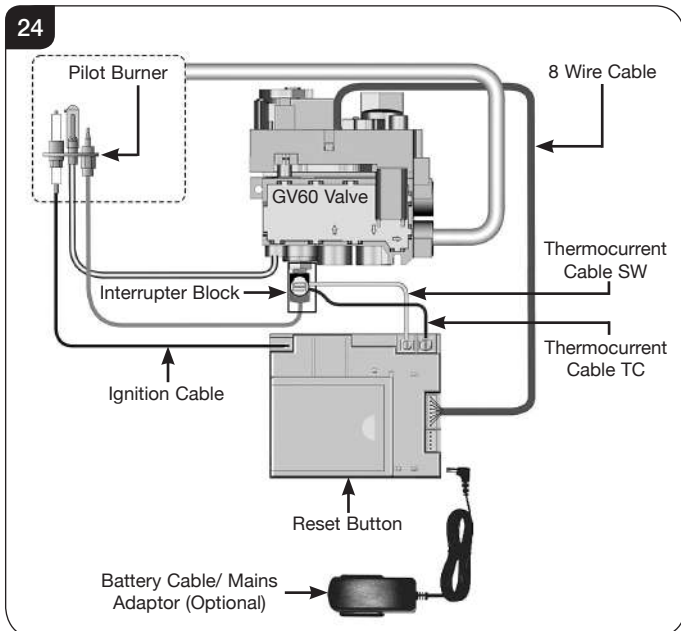

- 10.6 After replacing the control box you may need to reprogram the handset.
- Press and hold the reset button on the control box until you hear two signals. After the second longer signal:
 - Release the reset button and within 20 seconds:
 - Press the DOWN button on the handset until you hear two additional short signals confirming the new code is set. If there is a single long signal the code learning sequence has failed or the wiring is incorrect.

11. Main Injector

- 11.1 Remove the Main Burner as described in Servicing, Replacing Parts, Sections 4.
 11.2 Loosen and remove the nut from the injector pipe.
 11.3 Undo the 14mm lock nut that holds the pipe to the injector, see Diagram 25.

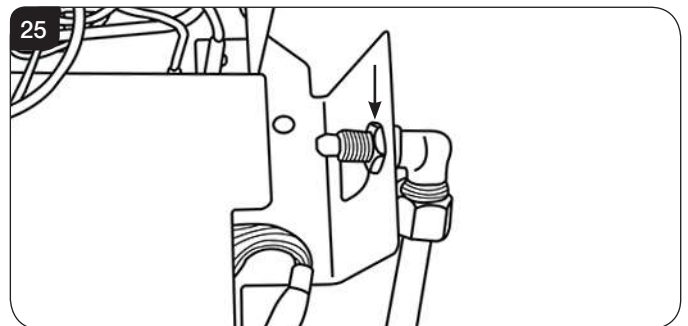

- 11.4 Replace with the correct size injector.
 11.5 Check for leaks.

12. Primary Aeration Plate

NOT ALL MODELS HAVE AERATION PLATES. REFER TO TECHNICAL SPECIFICATIONS, PAGE 11.

- 12.1 Remove the Main Burner as described in Servicing, Replacing Parts, Sections 4.
 12.2 Remove the 2 fixing nuts and slide the plate off the venturi.
 12.3 Replace with the correct size plate and secure with the nuts. Ensure the lower edge of the plate is located over the venturi flange, see Diagram 26.

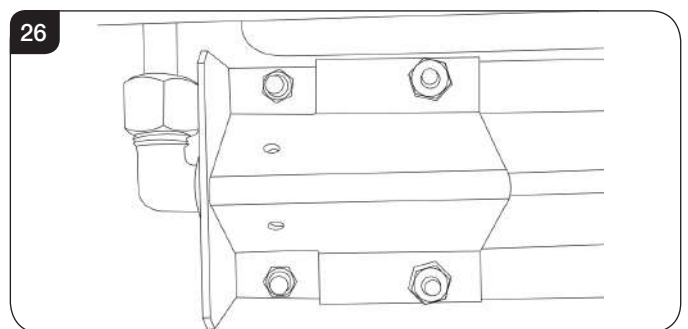

13. Changing Between Gas Types

In order to change between gas types, it will be necessary to change the complete burner module:

Contact your Gazco retailer for further information.

A kit of parts is available for this. Always quote the Model number and Serial number when ordering any spare parts.

Servicing Instructions - Replacing Parts

14. Debris Access Area

- 14.1 Remove the frame from the appliance by referring to the separate instructions supplied with the front.
- 14.2 Remove the glass frame, see Section 2 and the fuel bed components. Place carefully to one side.
- 14.3 Remove the baffle and liners, see Section 3.
- 14.4 Remove the main burner, see Section 4.
- 14.5 Remove the Control Assembly, see Section 5.
- 14.6 Undo the 2 screws on the back of the convector air panel, see Diagram 27.

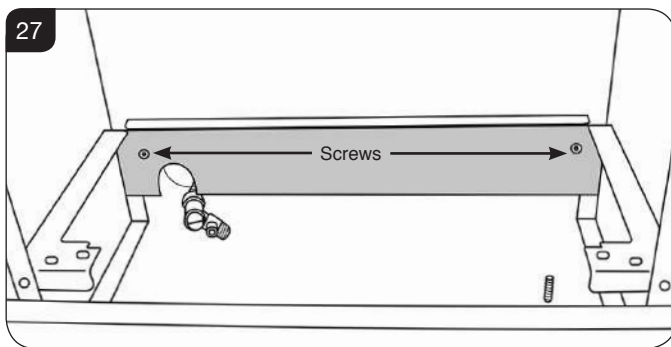

- 14.7 Pull the top of the air panel forwards to release, then tilt the bottom edge upwards into the firebox to remove.
- 14.8 Undo the 5 screws to remove the debris access plate, see Diagram 28.

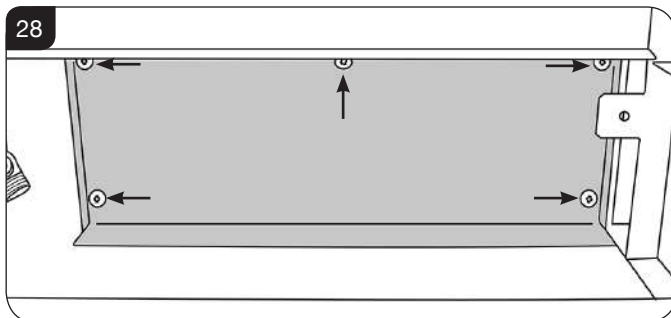

- 14.9 Clean out any debris.
- 14.10 To replace the convector air panel:
 - Angle the top edge of the panel up and under the lip at the back of the firebox.
 - Clip the panel into place and secure with the 2 previously removed screws.

Servicing Instructions - Replacing Parts

15. Spares List

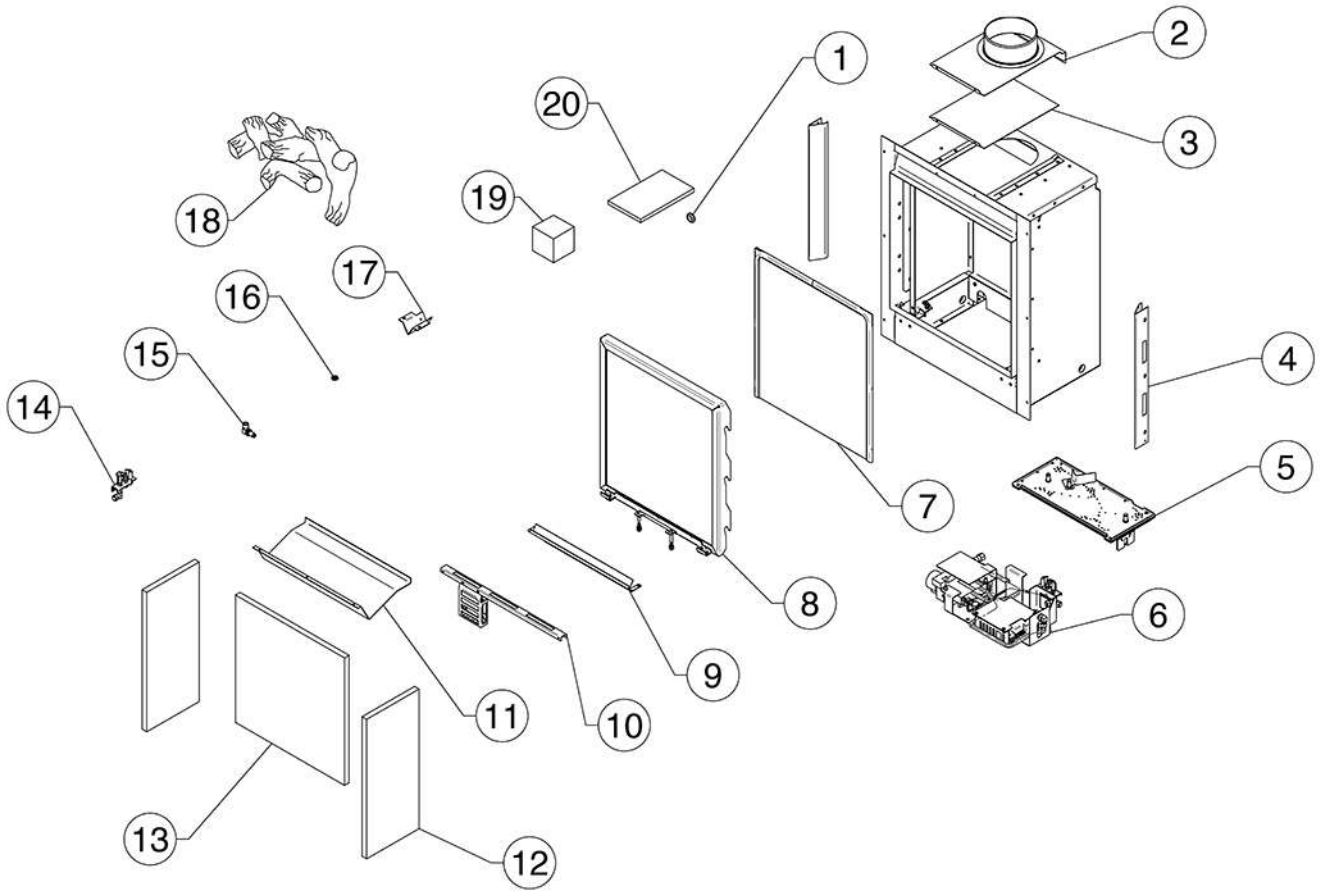

No.	Component	Part Code		
		Natural Gas	LPG	Quantity
1	Grommet	EL0022		4
2	Spigot Mounting Assembly	GZ13931		1
3	Spigot Blanking Plate	GZ14575		1
4	Side Frame Cover	GZ9695		2
5	Burner Assembly	GZ13930	GZ14534	1
6	Engine Assembly	GZ13923P	GZ13923N	1
7	Glass & Rope Seal Assembly	GZ13916		1
8	Door & Glass Assembly	GZ14685		1
9	Pebble Trough Assembly	GZ14488		1
10	Door Infill Trim Assembly	GZ13915		1
11	Top Baffle	GZ13898		1

No.	Component	Part Code		
		Natural Gas	LPG	Quantity
12	Side Lining Black Reed	CE1860		2
	Side Lining Vermiculite	CE1858		2
	Side Lining Black Glass	GZ14099		2
13	Rear Lining Black Reed	CE1861		1
	Rear Lining Vermiculite	CE1859		1
	Rear Lining Black Glass	GZ14094		1
14	Pilot Assembly	PI0036	PI0037	1
15	Injector	IN0053	IN0031	1
16	Injector Locknut	FA0241		1
17	Aeration Cover	GZ10405	GZ10409	1
18	Log Set	CE1755		1
19	Embaglow	GZ8471		1
20	Installation Kit	GZ14573		1



Due to continual technical improvements please check online or with your Gazco retailer for the most up to date parts lists.

Only use Genuine Gazco spares when servicing your appliance.

All of our essential spare parts and consumable items are available to purchase from our webshop at www.gazcospares.com.

Servicing Instructions - Replacing Parts

15. Spares List

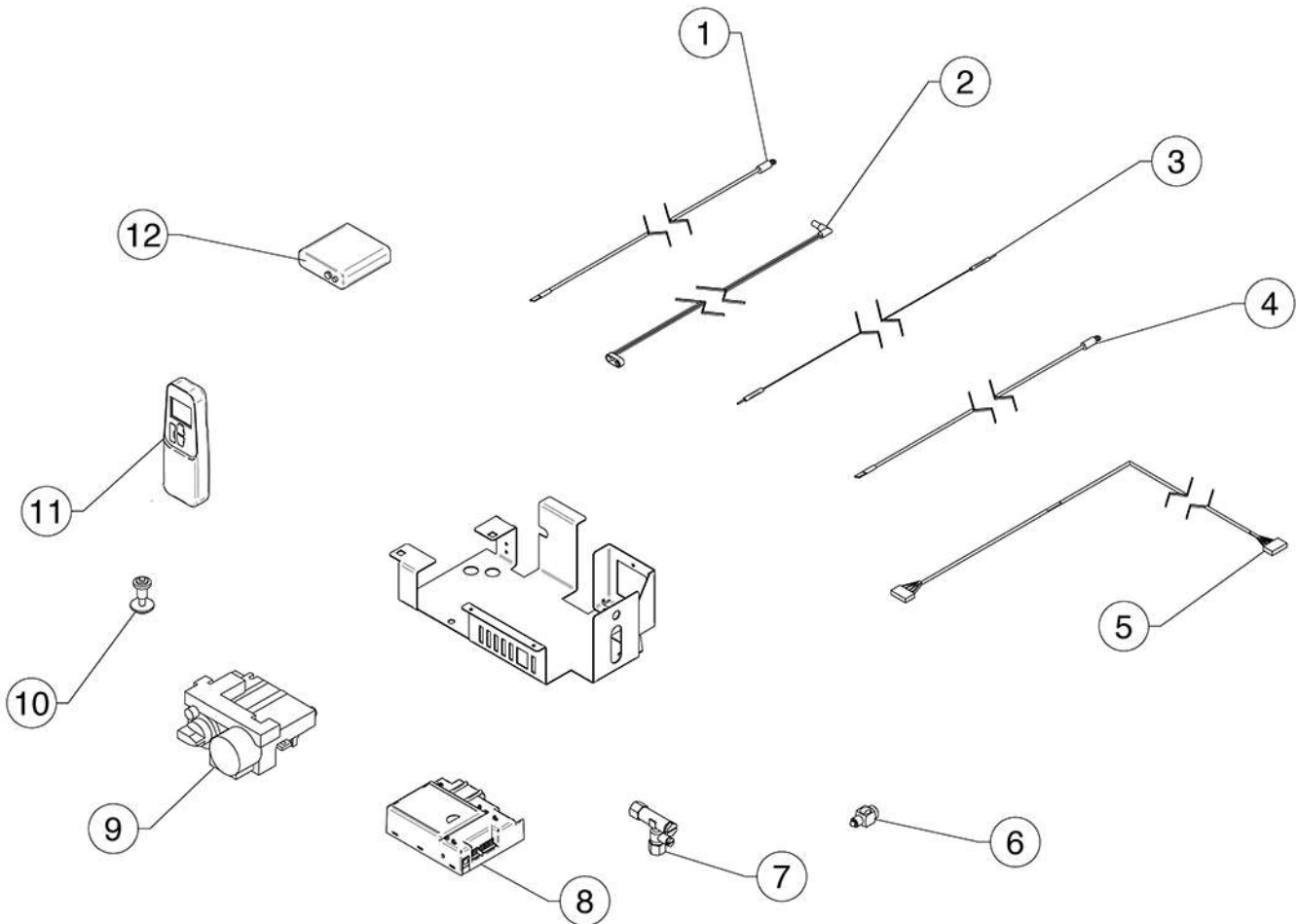

No.	Component	Part Code		
		Natural Gas	LPG	Quantity
1	Thermo Current Cable	EL0590		1
2	0.5m Battery Cable	GC0146		1
3	Ignition Cable	GC0125		1
4	Thermo Current Cable	GC0126		1
5	360mm Connection Cable	GC0133		1
6	Interrupter Block	GC0124		1
7	Pressure Test Restrictor Elbow	GC0095		1
8	Receiver	EL0589		1
9	Control Valve	GC0123K		1
10	Mag Unit	GC0166		1
11	Thermostatic Handset	EL0571		1
12	Battery Pack	EL0616		1



Due to continual technical improvements please check online or with your Gazco retailer for the most up to date parts lists.

Only use Genuine Gazco spares when servicing your appliance.

All of our essential spare parts and consumable items are available to purchase from our webshop at www.gazcospares.com.

Service Records

1ST SERVICE

Date of Service:.....
Next Service Due:.....
Signed:.....
Retailer's Stamp/GasSafe Registration Number

3RD SERVICE

Date of Service:.....
Next Service Due:.....
Signed:.....
Retailer's Stamp/GasSafe Registration Number

5TH SERVICE

Date of Service:.....
Next Service Due:.....
Signed:.....
Retailer's Stamp/GasSafe Registration Number

7TH SERVICE

Date of Service:.....
Next Service Due:.....
Signed:.....
Retailer's Stamp/GasSafe Registration Number

9TH SERVICE

Date of Service:.....
Next Service Due:.....
Signed:.....
Retailer's Stamp/GasSafe Registration Number

2ND SERVICE

Date of Service:.....
Next Service Due:.....
Signed:.....
Retailer's Stamp/GasSafe Registration Number

4TH SERVICE

Date of Service:.....
Next Service Due:.....
Signed:.....
Retailer's Stamp/GasSafe Registration Number

6TH SERVICE

Date of Service:.....
Next Service Due:.....
Signed:.....
Retailer's Stamp/GasSafe Registration Number

8TH SERVICE

Date of Service:.....
Next Service Due:.....
Signed:.....
Retailer's Stamp/GasSafe Registration Number

10TH SERVICE

Date of Service:.....
Next Service Due:.....
Signed:.....
Retailer's Stamp/GasSafe Registration Number

Information Requirement - Gas Heaters

Information Requirement for Gaseous Fuel Local Space Heater

Model	Riva2 400 CF NG	Riva2 400 CF LPG
Fuel		
Space Heating Emissions (NOx) - mg / kWh _{input} (GCV)	130	130
Heat Output		
Nominal Heat Output - P_{nom}	3.8kW	3.8kW
Minimum Heat Output (indicative) - P_{min}	1.7kW	1.6kW
Auxiliary Electricity Consumption		
At Nominal Heat Output - $e_{l,max}$	N/A	N/A
At Minimum Heat Output - $e_{l,min}$	N/A	N/A
In Standby Mode - $e_{l,sb}$	N/A	N/A
Useful Efficiency (NCV)		
Useful Efficiency at nominal heat output - $\eta_{th,nom}$	81.0%	81.0%
Useful Efficiency at minimum heat output (indicative) - $\eta_{th,min}$	71.0%	71.0%
Permanent Pilot Flame Power requirement		
Permanent Pilot Flame Power requirement (if applicable) - P_{pilot}	N/A	N/A
Type of heat output/room temperature control		
Electronic room temperature control + day timer	Yes	Yes
Other control options (multiple selections possible)		
Room temperature control, with presence detection	No	No
Room temperature control, with open window detection	No	No
With distance control option	No	No
With adaptive start control	No	No
With working time limitation	No	No
With black bulb sensor	No	No
Energy Efficiency Index	77.0%	77.0%
Energy Efficiency Class	C	C
Contact:	Gazco Ltd, Osprey Road, Sowton Industrial Estate, Exeter, EX2 7JG	

Gazco Limited, Osprey Road, Sowton Industrial Estate, Exeter, Devon, England EX2 7JG
Technical Customer Services: (01392) 261950 Fax: (01392) 261951
E-mail: technicalservices@gazco.com

A member of the Stovax Group

E & O E